

# Multiple Description Coding for Stationary Gaussian Sources

Jun Chen, *Member, IEEE*, Chao Tian, *Member, IEEE*, and Suhas Diggavi, *Member, IEEE*

**Abstract**—We consider the problem of multiple description coding for stationary Gaussian sources under the squared error distortion measure. The rate region is characterized for the 2-description case. It is shown that each supporting line of the rate region is achievable with a transform lattice quantization scheme. We show the optimal coding scheme has a natural spectral domain coding interpretation, which yields a reverse water-filling solution with a frequency-dependent water level instead of the flat water level as in the conventional single description case.

**Index Terms**—Gaussian source, lattice quantization, multiple description coding, power spectrum.

## I. INTRODUCTION

THE multiple description problem has received considerable attention as a model of information transmission over unreliable channels. The results on this problem are abundant. Notable work includes a general achievable rate region for the 2-description case by El Gamal and Cover (EGC) [1], the complete solution for the no-excess rate case by Ahlswede [2], and some conclusive results on binary multiple descriptions by Zhang and Berger [3]. However, the understanding of the multiple description problem for discrete sources is still very limited. More progress has been made on the quadratic Gaussian case. Arguably the most important work in this direction is the exact characterization of the 2-description rate region by Ozarow [4]. This result has been partially extended to the  $L$ -description case (with  $L > 2$ ) and the vector case in [5]–[8].

In contrast to the aforementioned results which are exclusively derived for independent and identically distributed (i.i.d.) sources, we shall consider multiple description coding for sources with memory, or more precisely, the discrete-time stationary Gaussian sources. The problem has been previously studied in [9]–[11], however, the complete characterization of the multiple description rate region for stationary Gaussian sources is still unknown. The main contribution of this work is an exact spectral domain characterization of the rate region for the 2-description case. Note that the 2-description problem

Manuscript received July 26, 2008; revised December 15, 2008. Current version published May 20, 2009. This work was supported in part by the Swiss National Science Foundation through NCCR-MICS.

J. Chen is with the Department of Electrical and Computer Engineering, McMaster University, Hamilton, ON L8S 4K1, Canada (e-mail: junchen@ece.mcmaster.ca).

C. Tian was with the School of Computer and Communication Sciences, Ecole Polytechnique Federale de Lausanne (EPFL), Lausanne, Switzerland. He is now with AT&T Labs-Research, Florham Park, NJ 07932 USA (e-mail: tian@research.att.com).

S. Diggavi is with the School of Computer and Communication Sciences, Ecole Polytechnique Federale de Lausanne (EPFL), Lausanne, Switzerland (e-mail: suhas.diggavi@epfl.ch).

Communicated by E. Ordentlich, Associate Editor for Source Coding.

Digital Object Identifier 10.1109/TIT.2009.2018178

for general stationary sources has been studied by Fleming and Effros [12]; however, the results in [12] are of multiletter type, which are in general not computable. In contrast, our spectral domain characterization allows one to perform numerical evaluation of the 2-description rate region for the stationary Gaussian sources.

The remainder of this paper is divided into four sections. In Section II, we introduce the definition of the 2-description problem for the stationary Gaussian sources. In Section III, we derive a lower bound on each supporting line of the 2-description rate region. In Section IV, this lower bound is shown to be achievable with a transform lattice quantization scheme. A spectral domain characterization of the rate region is given in Section V. We conclude the paper in Section VI.

Throughout this paper, we use operators  $\mathbb{E}[\cdot]$ ,  $\mathbb{E}[\cdot|\cdot]$ ,  $\det(\cdot)$ , and  $\text{tr}(\cdot)$  to denote expectation, conditional expectation, determinant, and trace, respectively; we use  $\|\cdot\|$  to denote the  $\ell^2$  norm and  $\preceq$  to denote positive semidefinite ordering.

## II. PROBLEM DEFINITION

Let  $\{X(t)\}_{t=1}^{\infty}$  be a zero-mean discrete-time stationary Gaussian process with autocorrelation function  $c(\tau) \triangleq \mathbb{E}[X(t)X(t-\tau)]$ ,  $\tau = 0, \pm 1, \pm 2, \dots$ . It is well known that there exists a positive measure  $\nu$  on  $[-\pi, \pi)$ , referred to as the power spectral distribution of  $\{X(t)\}_{t=1}^{\infty}$ , such that

$$c(\tau) = \frac{1}{2\pi} \int_{-\pi}^{\pi} e^{j\tau\omega} d\nu(\omega)$$

for all  $\tau$ . By a refined form of the Lebesgue decomposition theorem [13], we can write

$$\nu = \nu_1 + \nu_2 + \nu_3$$

where  $\nu_1$  is absolutely continuous with respect to Lebesgue measure  $\mu$ ,  $\nu_2$  is singular continuous, and  $\nu_3$  is a discrete measure. The power spectral density of  $\{X(t)\}_{t=1}^{\infty}$ , denoted as  $s(\omega)$ , is the Radon–Nikodym derivative of  $\nu_1$  with respect to Lebesgue measure  $\mu$ .

Mixing, weakly mixing, and ergodic processes are important classes of stationary processes (see [14], [15] for their definitions). Specifically, mixing implies weakly mixing, and weakly mixing implies ergodicity. For a zero-mean stationary Gaussian process  $\{X(t)\}_{t=1}^{\infty}$ , the following three conditions are equivalent:

- $\{X(t)\}_{t=1}^{\infty}$  is weakly mixing,
- $\{X(t)\}_{t=1}^{\infty}$  is ergodic,
- $\nu$  is continuous (i.e.,  $\nu_3 = 0$ ).

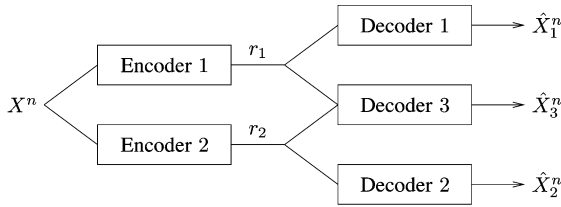

Fig. 1. Encoder and decoder diagram for multiple description coding.

Moreover,  $\{X(t)\}_{t=1}^\infty$  is mixing if and only if  $\lim_{\tau \rightarrow \infty} c(\tau) = 0$ . In particular, if  $\nu$  is absolutely continuous (i.e.,  $\nu = \nu_1$ ), then  $\{X(t)\}_{t=1}^\infty$  is mixing. Intuitively,  $\nu_2$  and  $\nu_3$  correspond to the perfectly predictable part of  $\{X(t)\}_{t=1}^\infty$  (cf. the Szegő–Kolmogorov–Krein theorem [16]), which in practice can usually be filtered out at the encoder end and reconstructed at the decoder end; therefore, we shall assume that  $\nu = \nu_1$ . Under this assumption, the process  $\{X(t)\}_{t=1}^\infty$  is mixing, and the covariance matrix  $K_{X^n}$  of  $X^n \triangleq (X(1), \dots, X(n))^T$  is positive definite for any positive integer  $n$ .

The formal definition of the 2-description problem is as follows (also see Fig. 1).

*Definition 1:* For a stationary Gaussian source  $\{X(t)\}_{t=1}^\infty$ , a rate pair  $(r_1, r_2)$  is called achievable with respect to the distortion constraints  $(d_1, d_2, d_3)$  if for all sufficiently large  $n$ , there exist encoding functions  $f_i^{(n)}(\cdot)$  on  $\mathcal{R}^n$  with  $\log |f_i^{(n)}| \leq nr_i$ ,  $i = 1, 2$ , such that

$$\frac{1}{n} \mathbb{E} \left[ \left\| X^n - \hat{X}_i^n \right\|^2 \right] \leq d_i, \quad i = 1, 2, 3$$

where  $\hat{X}_i^n = \mathbb{E}[X^n | f_i^{(n)}(X^n)]$ ,  $i = 1, 2$ , and  $\hat{X}_3^n = \mathbb{E}[X^n | f_1^{(n)}(X^n), f_2^{(n)}(X^n)]$  are the reconstruction for each decoder (see Fig. 1). The 2-description rate region  $\mathcal{R}(s(\omega), d_1, d_2, d_3)$  for the process  $\{X(t)\}_{t=1}^\infty$  is the convex closure of the set of all achievable rate pairs  $(r_1, r_2)$  with respect to the distortion constraints  $(d_1, d_2, d_3)$ . Without loss of generality, we shall assume  $\sigma_X^2 \geq d_i \geq d_3 > 0$ ,  $i = 1, 2$ , where  $\sigma_X^2 = \mathbb{E}[\|X(t)\|^2]$ .

Our main contribution in this work is a complete characterization of the rate region  $\mathcal{R}(s(\omega), d_1, d_2, d_3)$  and its spectral domain interpretation. Since  $\mathcal{R}(s(\omega), d_1, d_2, d_3)$  is a closed convex set, for the purpose of characterizing this set, it suffices to characterize its supporting lines, which is equivalent to solving the following optimization problem:

$$\kappa(\alpha, d_1, d_2, d_3) = \min_{(r_1, r_2) \in \mathcal{R}(s(\omega), d_1, d_2, d_3)} \alpha r_1 + (1 - \alpha) r_2, \quad \alpha \in [0, 1]. \quad (1)$$

A few remarks are now in place. It can be shown<sup>1</sup> that  $\kappa(\alpha, d_1, d_2, d_3)$  is not affected if in Definition 1 the desired

<sup>1</sup>Suppose for a specific  $n$  there exist encoding functions  $f_i^{(n)}(\cdot)$ ,  $i = 1, 2$ , that can meet the distortion constraints  $(d_1, d_2, d_3)$ . By concatenation we can construct encoding functions  $f_i^{(kn)}(\cdot)$ ,  $i = 1, 2$ , with the same rate–distortion performance for all  $kn$ ,  $k = 1, 2, \dots$ . Note that any sufficiently large integer  $m$  can be written as  $m = kn + j$  with  $0 \leq j < n$ . Given a source sequence of length  $m$ , we apply  $f_i^{(kn)}(\cdot)$ ,  $i = 1, 2$ , to the first  $kn$  symbols. The remaining  $j$  symbols can be easily handled by some fixed-rate quantizers such that the average reconstruction distortions of these  $i$  symbols meet the distortion constraints  $(d_1, d_2, d_3)$ . Since the contribution of these fixed-rate quantizers to the overall rates is negligible when  $m$  is large, the proof is complete.

encoding functions are not required to exist for all sufficiently large  $n$  but only for some  $n$ . Moreover, it can be shown through a standard time-sharing argument that  $\kappa(\alpha, d_1, d_2, d_3)$  is a convex function of  $(d_1, d_2, d_3)$  and therefore is continuous in  $(d_1, d_2, d_3)$ .

### III. OUTER BOUND

Now we proceed to derive a lower bound on  $\kappa(\alpha, d_1, d_2, d_3)$  for each  $\alpha \in [0, 1]$ , which in turn yields an outer bound on  $\mathcal{R}(s(\omega), d_1, d_2, d_3)$ . To this end, we shall relate  $\{X(t)\}_{t=1}^\infty$  with a block-independent process that is more amenable to analysis. Specifically, for each positive integer  $n$ , we construct a process  $\{X_n(t)\}_{t=1}^\infty$ , where  $(X_n(kn + 1), \dots, X_n(kn + n))^T \sim \mathcal{N}(0^n, K_{X^n})$ ,  $k = 0, 1, 2, \dots$ , and  $(X_n(kn + 1), \dots, X_n(kn + n))^T$  is independent of  $(X_n(k'n + 1), \dots, X_n(k'n + n))^T$  if  $k \neq k'$ . One can define the 2-description rate region for this constructed process as follows.

*Definition 2:* For a block-independent Gaussian source  $\{X_n(t)\}_{t=1}^\infty$ , a rate pair  $(r_1, r_2)$  is called achievable with respect to the distortion constraints  $(d_1, d_2, d_3)$  if for all sufficiently large  $m$ , there exist encoding functions  $f_i^{(mn)}(\cdot)$  on  $\mathcal{R}^{mn}$  with  $\log |f_i^{(mn)}| \leq mn r_i$ ,  $i = 1, 2$ , such that

$$\frac{1}{mn} \mathbb{E} \left[ \left\| X_n^{mn} - \hat{X}_{n,i}^{mn} \right\|^2 \right] \leq d_i, \quad i = 1, 2, 3$$

where

$$\hat{X}_{n,i}^{mn} = \mathbb{E}[X_n^{mn} | f_i^{(mn)}(X_n^{mn})], \quad i = 1, 2$$

and

$$\hat{X}_{n,3}^{mn} = \mathbb{E}[X_n^{mn} | f_1^{(mn)}(X_n^{mn}), f_2^{(mn)}(X_n^{mn})].$$

The 2-description rate region  $\mathcal{R}(K_{X^n}, d_1, d_2, d_3)$  for the process  $\{X_n(t)\}_{t=1}^\infty$  is the convex closure of the set of all achievable rate pairs  $(r_1, r_2)$  with respect to the distortion constraints  $(d_1, d_2, d_3)$ .

The above definition is closely related to the vector multiple description problem defined in [8]. The difference is that we require overall norm distortion constraints as seen above, whereas the vector multiple description problem needs to satisfy covariance distortion constraints. Therefore, clearly we can relate our problem to the vector multiple description characterization.

For  $n \times n$  symmetric positive definite matrices  $D_1, D_2$ , and  $D_3$ , define

$$\begin{aligned} \psi_n(K_{X^n}, D_1, D_2, D_3) &= \sup_{\Sigma} \log \left( \frac{\det(K_{X^n}) \det(K_{X^n} + \Sigma) \det(D_3 + \Sigma)}{\det(D_3) \det(D_1 + \Sigma) \det(D_2 + \Sigma)} \right) \end{aligned}$$

where the supremum is over all symmetric positive definite matrices  $\Sigma$ . It easily follows from the vector multiple description characterization in [8] that

$$\begin{aligned} \mathcal{R}(K_{X^n}, d_1, d_2, d_3) &= \bigcup_{D_1, D_2, D_3} \left\{ (r_1, r_2) : \right. \\ &\quad \left. r_i \geq \frac{1}{2n} \log \left( \frac{\det(K_{X^n})}{\det(D_i)} \right), i = 1, 2, \right. \\ &\quad \left. r_1 + r_2 \geq \frac{1}{2n} \psi_n(K_{X^n}, D_1, D_2, D_3) \right\} \quad (2) \end{aligned}$$

where the union is over all symmetric positive definite matrices  $(D_1, D_2, D_3)$  satisfying

$$\begin{aligned} D_3 &\preceq (D_1, D_2) \preceq K_{X^n}, \\ \frac{1}{n} \text{tr}(D_i) &\leq d_i, \quad i = 1, 2, 3. \end{aligned}$$

For the case  $n = 1$ , we shall denote  $\mathcal{R}(K_{X^n}, d_1, d_2, d_3)$  by  $\mathcal{R}(\sigma_X^2, d_1, d_2, d_3)$ . One can readily derive from (2) that

$$\begin{aligned} \mathcal{R}(\sigma_X^2, d_1, d_2, d_3) &= \left\{ (r_1, r_2) : r_i \geq \frac{1}{2} \log \left( \frac{\sigma_X^2}{d_i} \right), i = 1, 2, r_1 + r_2 \right. \\ &\quad \left. \geq \frac{1}{2} \psi(\sigma_X^2, d_1, d_2, d_3) \right\} \end{aligned}$$

where  $\psi(\sigma_X^2, d_1, d_2, d_3)$  is defined in the expressions at the bottom of the page. Note that  $\mathcal{R}(\sigma_X^2, d_1, d_2, d_3)$  is exactly Ozarow's 2-description rate region for i.i.d. Gaussian sources [4], and  $\min_{(r_1, r_2) \in \mathcal{R}(\sigma_X^2, d_1, d_2, d_3)} \alpha r_1 + (1 - \alpha)r_2$  is as shown in (4) also at the bottom of the page. When  $n \geq 2$ , the union operation in (2) cannot be removed, and the calculation becomes nontrivial. In view of the fact that  $\mathcal{R}(K_{X^n}, d_1, d_2, d_3)$  is a closed convex set, we shall characterize it by its supporting lines. Define

$$\kappa_n(\alpha, d_1, d_2, d_3) = \min_{(r_1, r_2) \in \mathcal{R}(K_{X^n}, d_1, d_2, d_3)} \alpha r_1 + (1 - \alpha)r_2, \quad \alpha \in [0, 1]. \quad (5)$$

Let  $K_{X^n} = U\Lambda^{(n)}U^T$  be the eigenvalue decomposition of  $K_{X^n}$ . Here  $U$  is a unitary matrix, and  $\Lambda^{(n)} = \text{diag}\{\lambda_1^{(n)}, \dots, \lambda_n^{(n)}\}$  is a positive definite diagonal matrix. Define a new process  $\{\tilde{X}_n(t)\}_{t=1}^\infty$  such that  $(\tilde{X}_n(kn+1), \dots, \tilde{X}_n(kn+n))^T = U^T(X_n(kn+1), \dots, X_n(kn+n))^T$ ,  $k = 0, 1, 2, \dots$ . It is clear that  $(\tilde{X}_n(kn+1), \dots, \tilde{X}_n(kn+n))^T \sim \mathcal{N}(0^n, \Lambda^{(n)})$  for all  $k$ . Since  $\{X_n(t)\}_{t=1}^\infty$  and  $\{\tilde{X}_n(t)\}_{t=1}^\infty$  are related by a unitary transform, it can be readily shown that

$$\mathcal{R}(K_{X^n}, d_1, d_2, d_3) = \mathcal{R}(\Lambda^{(n)}, d_1, d_2, d_3).$$

Therefore, we have

$$\kappa_n(\alpha, d_1, d_2, d_3) = \min_{(r_1, r_2) \in \mathcal{R}(\Lambda^{(n)}, d_1, d_2, d_3)} \alpha r_1 + (1 - \alpha)r_2, \quad \alpha \in [0, 1]. \quad (6)$$

The following lemma is of crucial importance for bounding  $\kappa_n(\alpha, d_1, d_2, d_3)$ .

*Lemma 1:* For any  $n \times n$  symmetric positive definite matrix  $\Xi = (\xi_{i,j})$  and positive definite diagonal matrix  $\Theta = \text{diag}\{\theta_1, \dots, \theta_n\}$ , we have

$$\frac{\det(\Xi + \Theta)}{\det(\Xi)} \geq \frac{\prod_{j=1}^n (\xi_{j,j} + \theta_j)}{\prod_{j=1}^n \xi_{j,j}}$$

with equality if and only if  $\Xi$  is diagonal.

*Proof:* Let  $S^n$  and  $N^n$  be two independent, zero-mean Gaussian  $n$ -dimensional random vectors with covariance matrices  $\Theta$  and  $\Xi$ , respectively. We have

$$\begin{aligned} &\frac{1}{2} \log \left[ \frac{\det(\Xi + \Theta)}{\det(\Xi)} \right] \\ &= I(S^n; S^n + N^n) \\ &= h(S^n) - h(S^n | S^n + N^n) \\ &= \sum_{j=1}^n (h(S(j)) - h(S(j) | S^n + N^n, S(1), \dots, S(j-1))) \\ &\geq \sum_{j=1}^n (h(S(j)) - h(S(j) | S(j) + N(j))) \\ &= \sum_{j=1}^n I(S(j); S(j) + N(j)) \\ &= \frac{1}{2} \log \left( \frac{\prod_{j=1}^n (\xi_{j,j} + \theta_j)}{\prod_{j=1}^n \xi_{j,j}} \right). \end{aligned}$$

The condition for equality clearly follows from the only inequality in the derivation.  $\square$

*Remark:* This lemma has an appealing "worst additive noise" interpretation, which is a specialization of the general problem treated in [17]. It essentially states that for an additive vector Gaussian channel, if the components of channel input signal

$$\begin{aligned} \psi(\sigma_X^2, d_1, d_2, d_3) &= \sup_{\sigma^2 > 0} \log \left( \frac{\sigma_X^2 (\sigma_X^2 + \sigma^2) (d_3 + \sigma^2)}{d_3 (d_1 + \sigma^2) (d_2 + \sigma^2)} \right) \\ &= \begin{cases} \log \left( \frac{\sigma_X^2}{d_3} \right), & d_3 < d_1 + d_2 - \sigma_X^2 \\ \log \left( \frac{\sigma_X^4}{d_1 d_2} \right), & d_3 > \left( \frac{1}{d_1} + \frac{1}{d_2} - \frac{1}{\sigma_X^2} \right)^{-1} \\ \log \left( \frac{\sigma_X^2 (\sigma_X^2 - d_3)^2}{d_3 \left( (\sigma_X^2 - d_3)^2 - \left( \sqrt{(\sigma_X^2 - d_1)(\sigma_X^2 - d_2)} - \sqrt{(d_1 - d_3)(d_2 - d_3)} \right)^2 \right)} \right), & \text{otherwise.} \end{cases} \end{aligned} \quad (3)$$

$$\min_{(r_1, r_2) \in \mathcal{R}(\sigma_X^2, d_1, d_2, d_3)} \alpha r_1 + (1 - \alpha)r_2 = \begin{cases} \frac{1-2\alpha}{2} \log \left( \frac{\sigma_X^2}{d_2} \right) + \frac{\alpha}{2} \psi(\sigma_X^2, d_1, d_2, d_3), & \alpha \in [0, \frac{1}{2}] \\ \frac{2\alpha-1}{2} \log \left( \frac{\sigma_X^2}{d_1} \right) + \frac{1-\alpha}{2} \psi(\sigma_X^2, d_1, d_2, d_3), & \alpha \in [\frac{1}{2}, 1]. \end{cases} \quad (4)$$

$S^n$  are independent Gaussian, then the components of the worst noise  $N^n$  under power constraint on each component are also independent.

Now we are ready to compute  $\kappa_n(\alpha, d_1, d_2, d_3)$ . First define  $\tilde{\kappa}_n(\alpha, d_1, d_2, d_3)$  as shown at the bottom of the page, where the minimization is over  $d_{i,j} (i = 1, 2, 3; j = 1, \dots, n)$  satisfying

$$d_{i,j} \in [0, \lambda_j^{(n)}], \quad i = 1, 2, 3, \quad j = 1, \dots, n,$$

$$\frac{1}{n} \sum_{j=1}^n d_{i,j} \leq d_i, \quad i = 1, 2, 3.$$

*Theorem 1:*  $\kappa_n(\alpha, d_1, d_2, d_3) = \tilde{\kappa}_n(\alpha, d_1, d_2, d_3)$ .

*Proof:* In view of (4), one can readily see  $\tilde{\kappa}_n(\alpha, d_1, d_2, d_3)$  is achievable by decomposing  $\{\tilde{X}_n(t)\}_{t=1}^\infty$  into  $n$  paralleled i.i.d. processes and then encoding them separately with a suitable distortion allocation. Therefore, we have  $\kappa_n(\alpha, d_1, d_2, d_3) \leq \tilde{\kappa}_n(\alpha, d_1, d_2, d_3)$ .

Now we proceed to show that  $\kappa_n(\alpha, d_1, d_2, d_3) \geq \tilde{\kappa}_n(\alpha, d_1, d_2, d_3)$ . By symmetry, we shall only consider the case  $\alpha \in [\frac{1}{2}, 1]$ . It follows from (2) and (6) that  $\kappa_n(\alpha, d_1, d_2, d_3)$  is given by the solution to the min-max problem

$$\kappa_n(\alpha, d_1, d_2, d_3) = \min_{D_1, D_2, D_3} \left\{ \frac{2\alpha - 1}{2n} \log \left( \frac{\det(\Lambda^{(n)})}{\det(D_1)} \right) + \sup_{\Sigma} \frac{1 - \alpha}{2n} \times \log \left( \frac{\det(\Lambda^{(n)}) \det(\Lambda^{(n)} + \Sigma) \det(D_3 + \Sigma)}{\det(D_3) \det(D_1 + \Sigma) \det(D_2 + \Sigma)} \right) \right\} \quad (7)$$

where the minimization is over all symmetric positive definite matrices  $(D_1, D_2, D_3)$  satisfying

$$D_3 \preceq (D_1, D_2) \preceq \Lambda^{(n)} \quad (8)$$

$$\frac{1}{n} \text{tr}(D_i) \leq d_i, \quad i = 1, 2, 3 \quad (9)$$

and the supremum is over all symmetric positive definite matrices  $\Sigma$ . By restricting  $\Sigma$  in (7) to be diagonal matrices, we get

$$\kappa_n(\alpha, d_1, d_2, d_3) \geq \min_{D_1, D_2, D_3} \left\{ \frac{2\alpha - 1}{2n} \log \frac{\det(\Lambda^{(n)})}{\det(D_1)} + \sup_{\Sigma = \text{diag}\{\sigma_1^2, \dots, \sigma_n^2\}, \sigma_j^2 > 0, j=1, \dots, n} \frac{1 - \alpha}{2n} \times \log \frac{\det(\Lambda^{(n)}) \det(\Lambda^{(n)} + \Sigma) \det(D_3 + \Sigma)}{\det(D_3) \det(D_1 + \Sigma) \det(D_2 + \Sigma)} \right\}. \quad (10)$$

For any symmetric positive definite matrix  $D_i$ , let  $\tilde{D}_i$  be a diagonal matrix with the same diagonal entries as those of  $D_i$ ,  $i = 1, 2, 3$ . If  $\Sigma$  is diagonal, then

$$\det(D_1) \leq \det(\tilde{D}_1),$$

$$\det(D_i + \Sigma) \leq \det(\tilde{D}_i + \Sigma), \quad i = 1, 2,$$

$$\frac{\det(D_3 + \Sigma)}{\det(D_3)} \geq \frac{\det(\tilde{D}_3 + \Sigma)}{\det(\tilde{D}_3)}$$

where the first two inequalities follow from Hadamard's inequality and the last one follows from Lemma 1. Therefore, for any symmetric positive definite matrices  $(D_1, D_2, D_3)$  and any positive definite diagonal matrix  $\Sigma$ , we have

$$\frac{2\alpha - 1}{2n} \log \frac{\det(\Lambda^{(n)})}{\det(D_1)} + \frac{1 - \alpha}{2n} \times \log \frac{\det(\Lambda^{(n)}) \det(\Lambda^{(n)} + \Sigma) \det(D_3 + \Sigma)}{\det(D_3) \det(D_1 + \Sigma) \det(D_2 + \Sigma)} \geq \frac{2\alpha - 1}{2n} \log \frac{\det(\Lambda^{(n)})}{\det(\tilde{D}_1)} + \frac{1 - \alpha}{2n} \times \log \frac{\det(\Lambda^{(n)}) \det(\Lambda^{(n)} + \Sigma) \det(\tilde{D}_3 + \Sigma)}{\det(\tilde{D}_3) \det(\tilde{D}_1 + \Sigma) \det(\tilde{D}_2 + \Sigma)}$$

which implies that

$$\frac{2\alpha - 1}{2n} \log \frac{\det(\Lambda^{(n)})}{\det(D_1)} + \sup_{\Sigma = \text{diag}\{\sigma_1^2, \dots, \sigma_n^2\}, \sigma_j^2 > 0, j=1, \dots, n} \frac{1 - \alpha}{2n} \times \log \frac{\det(\Lambda^{(n)}) \det(\Lambda^{(n)} + \Sigma) \det(D_3 + \Sigma)}{\det(D_3) \det(D_1 + \Sigma) \det(D_2 + \Sigma)} \geq \frac{2\alpha - 1}{2n} \log \frac{\det(\Lambda^{(n)})}{\det(\tilde{D}_1)} + \sup_{\Sigma = \text{diag}\{\sigma_1^2, \dots, \sigma_n^2\}, \sigma_j^2 > 0, j=1, \dots, n} \frac{1 - \alpha}{2n} \times \log \frac{\det(\Lambda^{(n)}) \det(\Lambda^{(n)} + \Sigma) \det(\tilde{D}_3 + \Sigma)}{\det(\tilde{D}_3) \det(\tilde{D}_1 + \Sigma) \det(\tilde{D}_2 + \Sigma)} \quad (11)$$

for any symmetric positive definite matrices  $(D_1, D_2, D_3)$ . Taking the minimization over all symmetric positive definite matrices  $(D_1, D_2, D_3)$  subject to the constraints (8) and (9) on the both sides of "≥" in (11) and substituting the resulting inequality into (10), we obtain

$$\kappa_n(\alpha, d_1, d_2, d_3) \geq \min_{D_1, D_2, D_3} \left\{ \frac{2\alpha - 1}{2n} \log \frac{\det(\Lambda^{(n)})}{\det(\tilde{D}_1)} \right\}$$

$$\tilde{\kappa}_n(\alpha, d_1, d_2, d_3) = \begin{cases} \min \left\{ \frac{1-2\alpha}{2n} \sum_{j=1}^n \log \left( \frac{\lambda_j^{(n)}}{d_{2,j}} \right) + \frac{\alpha}{2n} \sum_{j=1}^n \psi \left( \lambda_j^{(n)}, d_{1,j}, d_{2,j}, d_{3,j} \right) \right\}, & \alpha \in [0, \frac{1}{2}] \\ \min \left\{ \frac{2\alpha-1}{2n} \sum_{j=1}^n \log \left( \frac{\lambda_j^{(n)}}{d_{1,j}} \right) + \frac{1-\alpha}{2n} \sum_{j=1}^n \psi \left( \lambda_j^{(n)}, d_{1,j}, d_{2,j}, d_{3,j} \right) \right\}, & \alpha \in [\frac{1}{2}, 1] \end{cases}$$

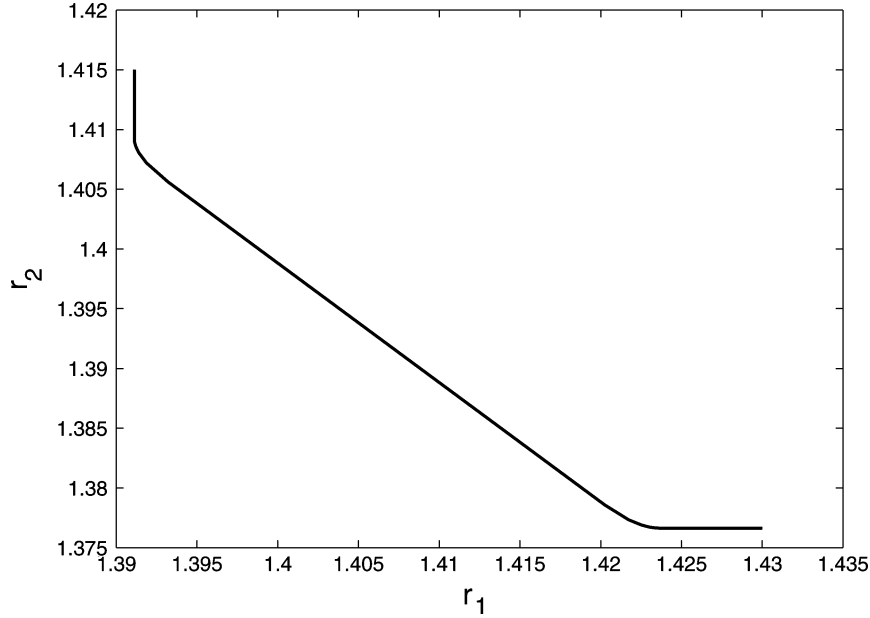

Fig. 2. The rate region (above and to the right of the given curve) with respect to the distortion constraints  $(d_1, d_2, d_3) = (3.4, 3.5, 1.5)$  for the block-independent Gaussian source with eigenvalues in Table I.

$$\begin{aligned}
 & + \sup_{\Sigma = \text{diag}\{\sigma_1^2, \dots, \sigma_n^2\}, \sigma_j^2 > 0, j=1, \dots, n} \frac{1-\alpha}{2n} \\
 & \times \log \frac{\det(\Lambda^{(n)}) \det(\Lambda^{(n)} + \Sigma) \det(\tilde{D}_3 + \Sigma)}{\det(\tilde{D}_3) \det(\tilde{D}_1 + \Sigma) \det(\tilde{D}_2 + \Sigma)} \Big\} \\
 = & \min_{\tilde{D}_1, \tilde{D}_2, \tilde{D}_3} \left\{ \frac{2\alpha-1}{2n} s \log \frac{\det(\Lambda^{(n)})}{\det(\tilde{D}_1)} \right. \\
 & \left. + \sup_{\Sigma = \text{diag}\{\sigma_1^2, \dots, \sigma_n^2\}, \sigma_j^2 > 0, j=1, \dots, n} \frac{1-\alpha}{2n} \right. \\
 & \left. \times \log \frac{\det(\Lambda^{(n)}) \det(\Lambda^{(n)} + \Sigma) \det(\tilde{D}_3 + \Sigma)}{\det(\tilde{D}_3) \det(\tilde{D}_1 + \Sigma) \det(\tilde{D}_2 + \Sigma)} \right\} \quad (12)
 \end{aligned}$$

where the minimizations in (12) is over all positive definite diagonal matrices  $(\tilde{D}_1, \tilde{D}_2, \tilde{D}_3)$  satisfying

$$\begin{aligned}
 \tilde{D}_3 & \preceq (\tilde{D}_1, \tilde{D}_2) \preceq \Lambda^{(n)} \\
 \frac{1}{n} \text{tr}(\tilde{D}_i) & \leq d_i, \quad i = 1, 2, 3.
 \end{aligned}$$

Using (3), it can be readily verified that (12) is equal to

$$\begin{aligned}
 \min \left\{ \frac{2\alpha-1}{2n} \sum_{j=1}^n \log \left( \frac{\lambda_j^{(n)}}{d_{1,j}} \right) \right. \\
 \left. + \frac{1-\alpha}{2n} \sum_{j=1}^n \psi \left( \lambda_j^{(n)}, d_{1,j}, d_{2,j}, d_{3,j} \right) \right\}
 \end{aligned}$$

where the minimization is over  $d_{i,j} (i = 1, 2, 3; j = 1, \dots, n)$  satisfying

$$\begin{aligned}
 0 < d_{3,j} \leq (d_{1,j}, d_{2,j}) \leq \lambda_j^{(n)}, \quad j = 1, \dots, n \\
 \frac{1}{n} \sum_{j=1}^n d_{i,j} \leq d_i, \quad i = 1, 2, 3. \quad (13)
 \end{aligned}$$

TABLE I  
OPTIMAL DISTORTION ALLOCATION WITH  $\alpha = 0.4$

$j$ -th eigenvalue	5	20	50	100	1000
$d_{1,j}$	2.6945	3.4601	3.5801	3.6168	3.6484
$d_{2,j}$	3.1472	3.5242	3.5900	3.6105	3.6282
$d_{3,j}$	1.7991	1.4888	1.4242	1.4032	1.3846

In view of the fact that

$$\psi(\lambda_j^{(n)}, d_{1,j}, d_{2,j}, d_{3,j}) = \log \left( \frac{\lambda_j^{(n)}}{d_{1,j}} \right) + \log \left( \frac{\lambda_j^{(n)}}{d_{2,j}} \right)$$

if  $d_{3,j} \geq \min\{d_{1,j}, d_{2,j}\}$ , the constraint  $d_{3,j} \leq (d_{1,j}, d_{2,j})$  in (13) can be safely dropped. Furthermore, we allow  $d_{i,j} = 0 (i = 1, 2, 3; j = 1, \dots, n)$  by using the convention that  $\log(\frac{a}{0}) = \infty$  for  $a > 0$ . The proof is complete.  $\square$

Now the problem of computing  $\kappa_n(\alpha, d_1, d_2, d_3)$  reduces to finding the optimal distortion allocation, which is a convex optimization problem. By varying  $\alpha$  within  $[0, 1]$ , the complete rate region  $\mathcal{R}(K_{X^n}, d_1, d_2, d_3)$  can be traced out. One such example is shown in Fig. 2 for the case  $n = 5$  with eigenvalues shown in Table I, where the optimal distortion allocation for a specific value of  $\alpha = 0.4$  is also given. In contrast to the case of i.i.d. Gaussian sources, the rate region cannot be completely characterized by three bounding lines. Instead, the region has two rounded corners and a straight line connecting them. Furthermore, it is worth noting that though  $\lambda_1^{(5)} < \lambda_5^{(5)}$ , the optimal distortion allocation actually gives  $d_{3,1} > d_{3,5}$ .

One fundamental property of  $\kappa_n(\alpha, d_1, d_2, d_3)$  is given by the following lemma.

*Lemma 2:*

$$\lim_{n \rightarrow \infty} \kappa_n(\alpha, d_1, d_2, d_3) = \inf_n \kappa_n(\alpha, d_1, d_2, d_3).$$

*Proof:* We shall show that the sequence  $\kappa_n(\alpha, d_1, d_2, d_3)$ ,  $n = 1, 2, \dots$ , is subadditive, i.e.,

$$(m+n)\kappa_{m+n}(\alpha, d_1, d_2, d_3) \leq m\kappa_m(\alpha, d_1, d_2, d_3) + n\kappa_n(\alpha, d_1, d_2, d_3) \quad (14)$$

for all positive integers  $m$  and  $n$ . The desired result then follows from Fekete's lemma.

Note that we can decompose  $\{X_{m+n}(t)\}_{t=1}^{\infty}$  into two block-independent processes with one equivalent to  $\{X_m(t)\}_{t=1}^{\infty}$  and the other equivalent to  $\{X_n(t)\}_{t=1}^{\infty}$ . Encode these two processes separately, both with distortion constraints  $(d_1, d_2, d_3)$ . This procedure effectively yields a coding scheme for  $\{X_{m+n}(t)\}_{t=1}^{\infty}$  that meets the distortion constraints  $(d_1, d_2, d_3)$ . Now one can readily derive (14) by combining this observation with Definition 2. The proof is complete.  $\square$

Now we shall return to the original problem to derive a lower bound on  $\kappa(\alpha, d_1, d_2, d_3)$  defined in (1).

*Theorem 2:*  $\kappa(\alpha, d_1, d_2, d_3) \geq \lim_{n \rightarrow \infty} \kappa_n(\alpha, d_1, d_2, d_3)$ .

*Proof:* Let  $f_1^{(n)}(\cdot)$  and  $f_2^{(n)}(\cdot)$  be two arbitrary encoding functions such that

$$\frac{1}{n} \mathbb{E} \left[ \left\| X^n - \hat{X}_i^n \right\|^2 \right] \leq d_i, \quad i = 1, 2, 3$$

where  $\hat{X}_i^n = \mathbb{E}[X^n | f_i^{(n)}(X^n)]$ ,  $i = 1, 2$ , and  $\hat{X}_3^n = \mathbb{E}[X^n | f_1^{(n)}(X^n), f_2^{(n)}(X^n)]$ . Since we can construct  $f_i^{(kn)}(\cdot)$  by concatenating  $k$  copies of  $f_i^{(n)}(\cdot)$  ( $i = 1, 2$ ) and apply them to  $\{X_n(t)\}_{t=1}^{\infty}$  to meet the distortion constraints  $(d_1, d_2, d_3)$ , it follows from Definition 2 and (5) that

$$\begin{aligned} \frac{\alpha}{n} \log \left| f_1^{(n)} \right| + \frac{1-\alpha}{n} \log \left| f_2^{(n)} \right| \\ \geq \kappa_n(\alpha, d_1, d_2, d_3) \\ \geq \inf_n \kappa_n(\alpha, d_1, d_2, d_3), \quad \alpha \in [0, 1]. \end{aligned}$$

Since  $\inf_n \kappa_n(\alpha, d_1, d_2, d_3)$  does not depend on  $n$ , it follows that  $\kappa(\alpha, d_1, d_2, d_3) \geq \inf_n \kappa_n(\alpha, d_1, d_2, d_3)$ . The proof is complete by invoking Lemma 2.  $\square$

#### IV. INNER BOUND

The main result of this section is the following theorem.

*Theorem 3:*  $\kappa(\alpha, d_1, d_2, d_3) \leq \lim_{n \rightarrow \infty} \kappa_n(\alpha, d_1, d_2, d_3)$ .

It is clear that the upper bound in Theorem 3 matches the lower bound in Theorem 2, yielding a complete characterization of  $\kappa(\alpha, d_1, d_2, d_3)$ . To prove Theorem 3, one may use the conventional approach based on the random coding argument. Such an approach, although conceptually straightforward, is technically nontrivial. Instead, we adopt a more constructive approach by showing that the lower bound is achievable using transform lattice quantization schemes. Two schemes are proposed: the first one is conceptually simpler while the second one is more efficient.

The first scheme, which is outlined below, adopts the conventional subband coding idea. We first break the source sequence into blocks of length  $n$ . Let  $K_{X^n}$  be the covariance matrix of each block and  $U\Lambda^{(n)}U^T$  be the eigenvalue decomposition of

$K_{X^n}$ . Multiply each block by the unitary matrix  $U^T$  to get  $n$  independent random variables with variances  $\lambda_1^{(n)}, \dots, \lambda_n^{(n)}$ , respectively. Note that the random variables are only independent within each block, but can be correlated across blocks. Now take  $m$  such blocks and group the  $j$ th symbol in each block to form a vector of length  $m$ . The random variables in the same vector are of the same variance  $\lambda_j^{(n)}$ , but they can be correlated. Next apply the multiple description lattice quantization scheme for i.i.d. scalar Gaussian sources [18] to each of these  $n$  vectors. Although the random variables in each vector may not be independent, it can be shown that the required rates can be upper-bounded by those for the i.i.d. case in the limit of large  $m$ . The desired result can now be obtained by sending  $n$  to infinity.

The major drawback of the first approach is that different vectors are coded separately, which causes loss of space-filling gain. Now let  $X^n = (X(1), \dots, X(n))^T$  be a source sequence of length  $n$ , and let  $\tilde{X}^n = U^T X^n$  with the covariance matrix  $\Lambda^{(n)} = \text{diag}\{\lambda_1^{(n)}, \dots, \lambda_n^{(n)}\}$ . The second approach directly works on  $\tilde{X}^n$ , therefore avoids the drawback of the first approach. Note the components of  $\tilde{X}^n$  have different variances, which renders the scheme in [18] not directly applicable. Fortunately, this problem can be circumvented by incorporating appropriate pre-filters and post-filters in the multiple description lattice quantization system proposed in [18].

Now we proceed to give a detailed analysis of the second approach. By symmetry, only the case  $\alpha \in [\frac{1}{2}, 1]$  will be treated.

Consider the successive multiple description quantization system depicted in Fig. 3. This system is based on entropy-coded dithered quantization (ECDQ). Here we quote some basic properties of ECDQ from [19]. Let  $Q_n(\cdot)$  be an optimal  $n$ -dimensional lattice quantizer (i.e., a lattice quantizer with the minimal normalized second moment  $G_n^{\text{opt}}$ ), and  $Z^n$  be a dither vector that is independent of the source and is uniformly distributed over the basic cell of the lattice. The lattice quantizer with dither represents the source vector  $S^n$  by the vector  $W^n = Q_n(S^n + Z^n) - Z^n$ .

- 1) The quantization error vector  $W^n - S^n$  is independent of  $S^n$  and is distributed as  $-Z^n$ . In particular, the mean-squared quantization error is given by the second moment of the dither, independently of the source distribution, i.e.,

$$\frac{1}{n} \mathbb{E}[\|W^n - S^n\|^2] = \frac{1}{n} \mathbb{E}[\|Z^n\|^2] = G_n^{\text{opt}} V^{2/n}$$

where  $V$  is the volume of the basic cell.

- 2) The coding rate of the ECDQ is equal to the mutual information between the input and output of an additive noise channel  $Y^n = S^n + N^n$ , where  $N^n$ , the channel's noise, has the same probability density function as  $-Z^n$

$$H(Q_n(S^n + Z^n) | Z^n) = I(S^n; Y^n) = h(Y^n) - h(N^n).$$

- 3) The autocorrelation of the quantizer noise is "white," i.e.,  $\mathbb{E}[Z^n (Z^n)^T] = \sigma^2 I$ , where  $I$  is an  $n \times n$  identity matrix and  $\sigma^2 = G_n^{\text{opt}} V^{2/n}$  is the second moment of the lattice.

Now let  $Q_n(\cdot)$  be an optimal  $n$ -dimensional lattice quantizer with the second moment  $\sigma^2 = 1$ . Let  $Z_1^n$  and  $Z_2^n$  be two independent  $n$ -dimensional dither vectors uniformly distributed over the basic cell of the lattice. Let  $d_{i,j}^*$  ( $i = 1, 2, 3; j = 1, \dots, n$ ) be the minimizer that achieves

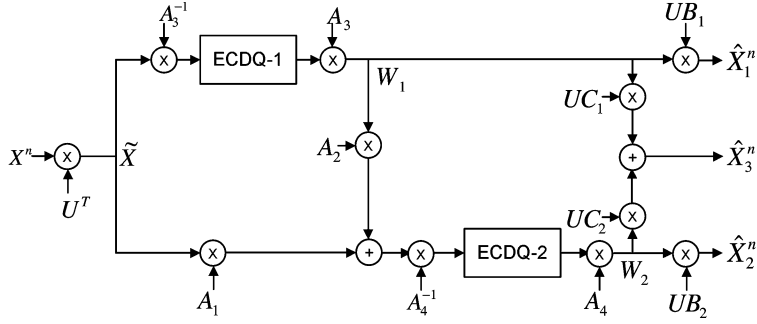

Fig. 3. Successive quantization.

$\kappa_n(\alpha, d_1, d_2, d_3)$ . Without loss of generality, it can be assumed that (see [8], [18] for a discussion regarding this point)

$$\left( \frac{1}{d_{1,j}^*} + \frac{1}{d_{2,j}^*} - \frac{1}{\lambda_j^{(n)}} \right)^{-1} \geq d_{3,j}^* \geq d_{1,j}^* + d_{2,j}^* - \lambda_j^{(n)},$$

$$j = 1, \dots, n.$$

Define

$$\sigma_{2,j}^2 = \frac{d_{i,j}^* \lambda_j^{(n)}}{\lambda_j^{(n)} - d_{i,j}^*} - \frac{d_{3,j}^* \lambda_j^{(n)}}{\lambda_j^{(n)} - d_{3,j}^*}, \quad i = 1, 2, \quad j = 1, \dots, n$$

$$\sigma_{3,j}^2 = \frac{d_{3,j}^* \lambda_j^{(n)}}{\lambda_j^{(n)} - d_{3,j}^*}, \quad j = 1, \dots, n.$$

Let  $A_i = \text{diag}\{a_{i,1}, \dots, a_{i,n}\}$ ,  $i = 1, 2, 3, 4$ , with

$$a_{1,j} = \frac{\sigma_{1,j}^2 + \sigma_{1,j}\sigma_{2,j}}{\sigma_{1,j}^2 + \sigma_{3,j}^2}, \quad j = 1, \dots, n$$

$$a_{2,j} = \frac{-\sigma_{1,j}\sigma_{2,j} + \sigma_{3,j}^2}{\sigma_{1,j}^2 + \sigma_{3,j}^2}, \quad j = 1, \dots, n$$

$$a_{3,j} = \sqrt{\sigma_{1,j}^2 + \sigma_{3,j}^2}, \quad j = 1, \dots, n$$

$$a_{4,j} = \frac{(\sigma_{1,j} + \sigma_{2,j})\sigma_{3,j}}{\sqrt{\sigma_{1,j}^2 + \sigma_{3,j}^2}}, \quad j = 1, \dots, n.$$

Furthermore, let

$$W_1^n = A_3 \left( Q_n \left( A_3^{-1} \tilde{X}^n + Z_1^n \right) - Z_1^n \right)$$

$$W_2^n = A_4 \left( Q_n \left( A_4^{-1} \left( A_1 \tilde{X}^n + A_2 W_1^n \right) + Z_2^n \right) - Z_2^n \right).$$

It can be verified that

$$\frac{1}{n} \mathbb{E} \left[ \left\| X^n - \hat{X}_i^n \right\|^2 \right] = \frac{1}{n} \mathbb{E} \left[ \left\| \tilde{X}^n - B_i W_i^n \right\|^2 \right]$$

$$= \frac{1}{n} \sum_{j=1}^n d_{i,j}^*$$

$$\leq d_i, \quad i = 1, 2$$

and

$$\frac{1}{n} \mathbb{E} \left[ \left\| X^n - \hat{X}_3^n \right\|^2 \right] = \frac{1}{n} \mathbb{E} \left[ \left\| \tilde{X}^n - \sum_{i=1}^2 C_i W_i^n \right\|^2 \right]$$

$$= \frac{1}{n} \sum_{j=1}^n d_{3,j}^*$$

$$\leq d_3,$$

where  $B_i = \text{diag}\{b_{i,1}, \dots, b_{i,n}\}$  and  $C_i = \text{diag}\{c_{i,1}, \dots, c_{i,n}\}$  are given by

$$b_{i,j} = \frac{\lambda_j^{(n)}}{\lambda_j^{(n)} + \sigma_{i,j}^2 + \sigma_{3,j}^2}, \quad i = 1, 2, \quad j = 1, \dots, n$$

$$c_{i,j} = \frac{\lambda_j^{(n)} \sigma_{1,j} \sigma_{2,j}}{\sigma_{i,j} (\sigma_{1,j} + \sigma_{2,j}) (\lambda_j^{(n)} + \sigma_{3,j}^2)}, \quad i = 1, 2, \quad j = 1, \dots, n.$$

Let  $N_i^n$  be an  $n$ -dimensional random vector distributed as  $-Z_i^n$ ,  $i = 1, 2$ . We have

$$r_1^{(n)} \triangleq \frac{1}{n} H \left( Q_n \left( A_3^{-1} \tilde{X}^n + Z_1^n \right) \middle| Z_1^n \right)$$

$$= \frac{1}{n} I \left( A_3^{-1} \tilde{X}^n; A_3^{-1} \tilde{X}^n + N_1^n \right)$$

$$= \frac{1}{n} h \left( A_3^{-1} \tilde{X}^n + N_1^n \right) - \frac{1}{n} h \left( N_1^n \right)$$

$$= \frac{1}{n} h \left( A_3^{-1} \tilde{X}^n + N_1^n \right) + \frac{1}{2} \log \left( G_n^{\text{opt}} \right)$$

$$\leq \frac{1}{2n} \sum_{j=1}^n \log \left( 2\pi e \left( a_{2,j}^{-2} \lambda_j^{(n)} + 1 \right) \right) + \frac{1}{2} \log \left( G_n^{\text{opt}} \right)$$

where the last inequality follows from the fact that for a given covariance matrix, the joint Gaussian distribution maximizes the differential entropy. Similarly

$$r_2^{(n)} \triangleq \frac{1}{n} H \left( Q_n \left( A_4^{-1} \left( A_1 \tilde{X}^n + A_2 W_1^n \right) + Z_2^n \right) \middle| Z_1^n, Z_2^n \right)$$

$$\leq \frac{1}{n} H \left( Q_n \left( A_4^{-1} \left( A_1 \tilde{X}^n + A_2 W_1^n \right) + Z_2^n \right) \middle| Z_2^n \right)$$

$$= \frac{1}{n} I \left( A_4^{-1} \left( A_1 \tilde{X}^n + A_2 W_1^n \right); \right.$$

$$\left. A_4^{-1} \left( A_1 \tilde{X}^n + A_2 W_1^n \right) + N_2^n \right)$$

$$= \frac{1}{n} h \left( A_4^{-1} \left( A_1 \tilde{X}^n + A_2 W_1^n \right) + N_2^n \right) - \frac{1}{n} h \left( N_2^n \right)$$

$$= \frac{1}{n} h \left( A_4^{-1} \left( A_1 \tilde{X}^n + A_2 W_1^n \right) + N_2^n \right)$$

$$+ \frac{1}{2} \log \left( G_n^{\text{opt}} \right)$$

$$= \frac{1}{n} h \left( A_4^{-1} \left( A_1 \tilde{X}^n + A_2 \tilde{X}^n \right. \right.$$

$$\left. \left. + A_2 A_3 N_1^n \right) + N_2^n \right) + \frac{1}{2} \log \left( G_n^{\text{opt}} \right)$$

$$\leq \frac{1}{2n} \sum_{j=1}^n \log \left( 2\pi e \left( a_{4,j}^{-2} \left( (a_{1,j} + a_{2,j})^2 \lambda_j^{(n)} \right. \right. \right.$$

$$\left. \left. + a_{2,j}^2 a_{3,j}^2 \right) + 1 \right) \right) + \frac{1}{2} \log \left( G_n^{\text{opt}} \right).$$

Therefore, we have

$$\begin{aligned}
 & \alpha r_1^{(n)} + (1-\alpha)r_2^{(n)} \\
 &= \frac{\alpha}{n} H \left( Q_n \left( A_3^{-1} \tilde{X}^n + Z_1^n \right) \middle| Z_1^n \right) \\
 & \quad + \frac{1-\alpha}{n} H \left( Q_n \left( A_4^{-1} \left( A_1 \tilde{X}^n + A_2 W_1^n \right) + Z_2^n \right) \middle| Z_1^n, Z_2^n \right) \\
 & \leq \frac{\alpha}{2n} \sum_{j=1}^n \log \left( 2\pi e \left( a_{2,j}^{-2} \lambda_j^{(n)} + 1 \right) \right) \\
 & \quad + \frac{1-\alpha}{2n} \\
 & \quad \times \sum_{j=1}^n \log \left( 2\pi e \left( a_{4,j}^{-2} \left( (a_{1,j} + a_{2,j})^2 \lambda_j^{(n)} + a_{2,j}^2 a_{3,j}^2 \right) + 1 \right) \right) \\
 & \quad + \frac{1}{2} \log \left( G_n^{\text{opt}} \right) \\
 &= \kappa_n(\alpha, d_1, d_2, d_3) + \frac{1}{2} \log \left( 2\pi e G_n^{\text{opt}} \right).
 \end{aligned}$$

If one interprets  $r_1^{(n)}$  and  $r_2^{(n)}$  as the rates of encoding functions 1 and 2, respectively, then the desired result follows from the fact that  $G_n^{\text{opt}} \rightarrow \frac{1}{2\pi e}$  as  $n \rightarrow \infty$ .

Although for the purpose of characterizing the multiple description rate region  $\mathcal{R}(s(\omega), d_1, d_2, d_3)$  it suffices to show that each of its supporting lines is achievable by the proposed scheme, it does not imply that this scheme can achieve an arbitrary point in the rate region. Indeed, the interior points of the minimum sum-rate line<sup>2</sup> of  $\mathcal{R}(s(\omega), d_1, d_2, d_3)$  is not directly attainable through the current scheme. Nevertheless, those points can be attained by either time-sharing of the given successive quantization scheme or using the splitting method proposed in [18].

In the analysis of the proposed scheme, we have implicitly made the following two assumptions:

- 1) the dither vectors  $Z_1^n$  and  $Z_2^n$  are known at both the encoder and the decoder;
- 2) the output of each quantizer is entropy-coded (conditioned on the dither sample) using ideal lossless variable-rate codes.

However, in Definition 1, only fixed-rate codes are allowed, and no common randomness is permitted. There are two ways to resolve this inconsistency. First, one can modify Definition 1 to allow variable-rate codes and common randomness. It can be verified that the outer bound derived in Section III is not affected by the modification of the definition. In particular, the converse argument in [8] continues to hold even if variable-rate codes and common randomness are allowed. Second, one may modify the

<sup>2</sup>The minimum sum-rate line of  $\mathcal{R}(s(\omega), d_1, d_2, d_3)$  is the set of points in  $\mathcal{R}(s(\omega), d_1, d_2, d_3)$  that minimize the sum-rate, i.e.,  $\{(r_1, r_2) \in \mathcal{R}(s(\omega), d_1, d_2, d_3) : r_1 + r_2 = \min_{(r_1', r_2') \in \mathcal{R}(s(\omega), d_1, d_2, d_3)} r_1' + r_2'\}$ .

proposed scheme to meet the conditions of Definition 1. This approach is more technical, and an argument is outlined in the Appendix. It is worth noting that in contrast to variable-rate codes for which no ergodicity assumption on the source is required, such kind of assumption is needed for fixed-rate codes in order to relate the entropy rate with the code rate.

### V. A SPECTRAL DOMAIN CHARACTERIZATION

By Theorems 2 and 3, we have

$$\kappa(\alpha, d_1, d_2, d_3) = \lim_{n \rightarrow \infty} \kappa_n(\alpha, d_1, d_2, d_3). \quad (15)$$

In view of Theorem 1 and Szegő's limit theorem, it is natural to conjecture that  $\kappa(\alpha, d_1, d_2, d_3)$  has a spectral domain characterization. However, it is technically nontrivial to obtain such a characterization via Szegő's limit theorem since  $\kappa_n(\alpha, d_1, d_2, d_3)$  is given in the form of a minimization problem, which does not seem to have an explicit solution. Nevertheless, the conjecture is indeed true, as we shall show in the sequel. This essentially yields a generalization of the conventional reverse water-filling solution for the single description case; however, here the water level is frequency-dependent instead of being flat across the spectrum.

It is worth emphasizing that although  $\kappa_n(\alpha, d_1, d_2, d_3)$  can be evaluated by solving a convex optimization problem, it is in general infeasible to compute  $\kappa(\alpha, d_1, d_2, d_3)$  via (15). In contrast, it will be seen that the spectral domain characterization of  $\kappa(\alpha, d_1, d_2, d_3)$  not only provides an alternative expression but also suggests a way for numerical evaluation.

Define  $\tilde{\kappa}(\alpha, d_1, d_2, d_3)$  as shown at the bottom of the page, where the infimum is over  $d_i(\omega)$ ,  $i = 1, 2, 3$ ,  $\omega \in [-\pi, \pi)$ , satisfying

$$\begin{aligned}
 & d_i(\omega) \in [0, s(\omega)], \quad i = 1, 2, 3, \quad \omega \in [-\pi, \pi) \\
 & \frac{1}{2\pi} \int_{-\pi}^{\pi} d_i(\omega) d\omega \leq d_i, \quad i = 1, 2, 3.
 \end{aligned}$$

Here we use the convention that  $\log(\frac{0}{0}) = 0$  and  $\log(\frac{a}{0}) = \infty$  for  $a > 0$ . The spectral domain characterization is formally given in the following theorem.

*Theorem 4:*  $\kappa(\alpha, d_1, d_2, d_3) = \tilde{\kappa}(\alpha, d_1, d_2, d_3)$ .

The following lemmas are needed for proving Theorem 4.

*Lemma 3:*  $\tilde{\kappa}(\alpha, d_1, d_2, d_3)$  is a continuous convex function of  $(d_1, d_2, d_3)$ .

*Proof:* This result follows from the fact that  $\log(\frac{s(\omega)}{d_1(\omega)})$ ,  $\log(\frac{s(\omega)}{d_2(\omega)})$ , and  $\psi(s(\omega), d_1(\omega), d_2(\omega), d_3(\omega))$  are convex functions of  $(d_1(\omega), d_2(\omega), d_3(\omega))$ .  $\square$

*Lemma 4:* The set  $\mathcal{Y}^+ = \{y : \mu(\{\omega : s(\omega) = y\}) > 0\}$  is countable.

$$\tilde{\kappa}(\alpha, d_1, d_2, d_3) = \begin{cases} \inf \left\{ \frac{1-2\alpha}{4\pi} \int_{-\pi}^{\pi} \log \left( \frac{s(\omega)}{d_2(\omega)} \right) d\omega + \frac{\alpha}{4\pi} \int_{-\pi}^{\pi} \psi(s(\omega), d_1(\omega), d_2(\omega), d_3(\omega)) d\omega \right\}, & \alpha \in [0, 1/2) \\ \inf \left\{ \frac{2\alpha-1}{4\pi} \int_{-\pi}^{\pi} \log \left( \frac{s(\omega)}{d_1(\omega)} \right) d\omega + \frac{1-\alpha}{4\pi} \int_{-\pi}^{\pi} \psi(s(\omega), d_1(\omega), d_2(\omega), d_3(\omega)) d\omega \right\}, & \alpha \in [1/2, 1] \end{cases}$$

*Proof:* Let  $\mathcal{Y}_m^+ = \{y : \mu(\{\omega : s(\omega) = y\}) > \frac{1}{m}\}$ . It is clear that  $\mathcal{Y}_m^+$  is a finite set for any positive integer  $m$ . Since  $\mathcal{Y}^+ = \bigcup_m \mathcal{Y}_m^+$ , we can see that  $\mathcal{Y}^+$  must be a countable set.  $\square$

*Lemma 5:*  $\lim_{y \rightarrow \infty} \int_{s(\omega) > y} s(\omega) d\omega = 0$ .

*Proof:* A simple application of the monotone convergence theorem yields the desired result.  $\square$

*Lemma 6:* If  $\mu(\{\omega : s(\omega) = y\}) = 0$ , then

$$\lim_{n \rightarrow \infty} \frac{1}{n} \sum_{j=1}^n \lambda_j^{(n)} \mathbb{1}(\lambda_j^{(n)} \leq y) = \frac{1}{2\pi} \int_{s(\omega) \leq y} s(\omega) d\omega$$

$$\lim_{n \rightarrow \infty} \frac{1}{n} \sum_{j=1}^n \mathbb{1}(\lambda_j^{(n)} \leq y) = \frac{1}{2\pi} \mu(\{\omega : s(\omega) \leq y\})$$

where  $\mathbb{1}(\cdot)$  is the indicator function.

*Remark:* See Section III for the definition of  $\lambda_j^{(n)}$ ,  $j = 1, \dots, n$ . This lemma is a simple consequence of Szegő's limit theorem [20] (also see [21]). Note that by Lemma 4, the condition in Lemma 6 is met by all  $y \geq 0$  except for countable number of points.

Now we proceed to prove Theorem 4. Specifically, we shall show that for any  $\delta > 0$

$$\begin{aligned} \tilde{\kappa}(\alpha, d_1 + \delta, d_2 + \delta, d_3 + \delta) \\ \leq \kappa_n(\alpha, d_1, d_2, d_3) \\ \leq \tilde{\kappa}(\alpha, d_1 - \delta, d_2 - \delta, d_3 - \delta) \end{aligned}$$

when  $n$  is sufficiently large, and then complete the proof by invoking Lemma 3. The key idea is to approximate  $\kappa_n(\alpha, d_1, d_2, d_3)$  and  $\tilde{\kappa}(\alpha, d_1, d_2, d_3)$  by convex optimization problems for certain piecewise constant functions so that a direct comparison becomes possible. By symmetry, we shall only consider the case  $\alpha \in [\frac{1}{2}, 1]$ .

*Proof:* For any  $\epsilon > 0$ , one can find  $0 < \beta_1 < \beta_2 < \dots < \beta_M$  for some positive integer  $M$  such that

$$\frac{\beta_{m+1}}{\beta_m} \leq 1 + \epsilon, \quad m = 1, \dots, M-1 \quad (16)$$

$$\mu(\{\omega : s(\omega) = \beta_m\}) = 0, \quad m = 1, \dots, M \quad (17)$$

$$\frac{1}{2\pi} \int_{s(\omega) \leq \beta_1} s(\omega) d\omega \leq \epsilon \quad (18)$$

$$\frac{1}{2\pi} \int_{s(\omega) > \beta_M} s(\omega) d\omega \leq \epsilon \quad (19)$$

where (17) is guaranteed by Lemma 4, and (19) is guaranteed by Lemma 5. Define

$$\begin{aligned} \mathcal{S}_m^{(n)} &= \left\{ j : \lambda_j^{(n)} \in (\beta_m, \beta_{m+1}] \right\}, \quad m = 1, \dots, M-1 \\ \Omega_m &= \{\omega : s(\omega) \in (\beta_m, \beta_{m+1}]\}, \quad m = 1, \dots, M-1. \end{aligned}$$

Let  $\mathcal{J}_m^{(n)}$  be a subset of  $\mathcal{S}_m^{(n)}$  such that  $|\mathcal{J}_m^{(n)}|$  is the largest integer satisfying  $|\mathcal{J}_m^{(n)}| \leq |\mathcal{S}_m^{(n)}|$  and  $\frac{|\mathcal{J}_m^{(n)}|}{n} \leq \frac{1}{2\pi} \mu(\Omega_m)$ ,  $m = 1, \dots, M-1$ . Let  $\Omega_m^{(n)}$  be a measurable subset of  $\Omega_m$  such that

$$\frac{1}{2\pi} \mu(\Omega_m^{(n)}) = \frac{|\mathcal{J}_m^{(n)}|}{n}, \quad m = 1, \dots, M-1.$$

Define

$$\bar{\lambda}_j^{(n)} = \begin{cases} \beta_{m+1}, & j \in \mathcal{J}_m^{(n)} \text{ for some } m \\ \lambda_j^{(n)}, & \text{otherwise} \end{cases} \quad j = 1, \dots, n$$

$$\underline{\lambda}_j^{(n)} = \begin{cases} \beta_m, & j \in \mathcal{J}_m^{(n)} \text{ for some } m \\ \lambda_j^{(n)}, & \text{otherwise} \end{cases} \quad j = 1, \dots, n$$

$$\bar{s}_n(\omega) = \begin{cases} \beta_{m+1}, & \omega \in \Omega_m^{(n)} \text{ for some } m \\ s(\omega), & \text{otherwise} \end{cases} \quad \omega \in [-\pi, \pi)$$

$$\underline{s}_n(\omega) = \begin{cases} \beta_m, & \omega \in \Omega_m^{(n)} \text{ for some } m \\ s(\omega), & \text{otherwise} \end{cases} \quad \omega \in [-\pi, \pi).$$

Let

$$\mathcal{J}^{(n)} = \bigcup_{m=1}^{M-1} \mathcal{J}_m^{(n)}$$

and

$$\mathcal{J}^{(n),c} = \{1, \dots, n\} \setminus \bigcup_{m=1}^{M-1} \mathcal{J}_m^{(n)}.$$

It is easy to see that

$$\begin{aligned} \kappa_n(\alpha, d_1, d_2, d_3) \\ \leq \min \left\{ \frac{2\alpha - 1}{2n} \sum_{j=1}^n \log \left( \frac{\bar{\lambda}_j^{(n)}}{d_{1,j}} \right) \right. \\ \left. + \frac{1 - \alpha}{2n} \sum_{j=1}^n \psi \left( \bar{\lambda}_j^{(n)}, d_{1,j}, d_{2,j}, d_{3,j} \right) \right\} \quad (20) \\ \leq \min \left\{ \frac{2\alpha - 1}{2n} \sum_{m=1}^{M-1} \sum_{j \in \mathcal{J}_m^{(n)}} \log \left( \frac{\beta_{m+1}}{d_{1,j}} \right) \right. \\ \left. + \frac{1 - \alpha}{2n} \sum_{m=1}^{M-1} \sum_{j \in \mathcal{J}_m^{(n)}} \psi(\beta_{m+1}, d_{1,j}, d_{2,j}, d_{3,j}) \right\} \\ \triangleq \bar{\kappa}_n(\alpha, d_1, d_2, d_3) \quad (21) \end{aligned}$$

where the minimization in (20) is over  $d_{i,j}$  ( $i = 1, 2, 3; j = 1, \dots, n$ ) subject to the constraints

$$\begin{aligned} d_{i,j} &\in [0, \bar{\lambda}_j^{(n)}], \quad i = 1, 2, 3, \quad j = 1, \dots, n \\ \frac{1}{n} \sum_{j=1}^n d_{i,j} &\leq d_i, \quad i = 1, 2, 3 \end{aligned}$$

and the minimization in (21) is over  $d_{i,j}$  ( $i = 1, 2, 3; j \in \mathcal{J}^{(n)}$ ) subject to the constraints

$$\begin{aligned} d_{i,j} &\in [0, \bar{\lambda}_j^{(n)}], \quad i = 1, 2, 3, \quad j \in \mathcal{J}^{(n)} \\ \frac{1}{n} \sum_{j \in \mathcal{J}^{(n)}} d_{i,j} &\leq d_i - \frac{1}{n} \sum_{j \in \mathcal{J}^{(n),c}} \lambda_j^{(n)}, \quad i = 1, 2, 3. \end{aligned}$$

The inequality in (20) is by the fact that  $\kappa_n(\alpha, d_1, d_2, d_3)$ , as an implicit function of  $(\lambda_1^{(n)}, \dots, \lambda_n^{(n)})$ , is monotonically increasing. The inequality in (21) follows from the fact that one

can convert the minimization problem in (20) to the one in (21) by imposing an additional constraint

$$d_{i,j} = \lambda_j^{(n)}, \quad i = 1, 2, 3, \quad j \in \mathcal{J}^{(n),c}.$$

By Jensen's inequality, we have

$$\begin{aligned} & \sum_{j \in \mathcal{J}_m^{(n)}} \log \left( \frac{\beta_{m+1}}{d_{1,j}} \right) \\ & \geq |\mathcal{J}_m^{(n)}| \log \left( \frac{\beta_{m+1}}{\frac{1}{|\mathcal{J}_m^{(n)}|} \sum_{j \in \mathcal{J}_m^{(n)}} d_{1,j}} \right), \quad m = 1, \dots, M-1 \\ & \sum_{j \in \mathcal{J}_m^{(n)}} \psi(\beta_{m+1}, d_{1,j}, d_{2,j}, d_{3,j}) \\ & \geq |\mathcal{J}_m^{(n)}| \psi \left( \beta_{m+1}, \frac{1}{|\mathcal{J}_m^{(n)}|} \sum_{j \in \mathcal{J}_m^{(n)}} d_{1,j}, \frac{1}{|\mathcal{J}_m^{(n)}|} \sum_{j \in \mathcal{J}_m^{(n)}} d_{2,j}, \frac{1}{|\mathcal{J}_m^{(n)}|} \sum_{j \in \mathcal{J}_m^{(n)}} d_{3,j} \right), \quad m = 1, \dots, M-1. \end{aligned}$$

Therefore, there is no loss of generality in assuming  $d_{i,j} = d_{i,j'}$  in (21) if  $j, j' \in \mathcal{J}_m^{(n)}$  for some  $m$ . Let  $\Omega^{(n)} = \bigcup_{m=1}^{M-1} \Omega_m^{(n)}$  and  $\Omega^{(n),c} = [-\pi, \pi] \setminus \bigcup_{m=1}^{M-1} \Omega_m^{(n)}$ . Define

$$\begin{aligned} & \bar{\kappa}'_n(\alpha, d_1, d_2, d_3) \\ & = \min \left\{ \frac{2\alpha-1}{4\pi} \sum_{m=1}^{M-1} \int_{\Omega_m^{(n)}} \log \left( \frac{\beta_{m+1}}{d_1(\omega)} \right) d\omega \right. \\ & \quad \left. + \frac{1-\alpha}{4\pi} \sum_{m=1}^{M-1} \int_{\Omega_m^{(n)}} \psi(\beta_{m+1}, d_1(\omega), d_2(\omega), d_3(\omega)) d\omega \right\} \quad (22) \end{aligned}$$

where the minimization is over  $d_i(\omega), i = 1, 2, 3, \omega \in \Omega^{(n)}$ , subject to the constraints

$$\begin{aligned} & d_i(\omega) \in [0, \bar{s}(\omega)], \quad i = 1, 2, 3, \quad \omega \in \Omega^{(n)} \\ & \frac{1}{2\pi} \int_{\Omega^{(n)}} d_i(\omega) d\omega \leq d_i - \frac{1}{n} \sum_{j \in \mathcal{J}^{(n),c}} \lambda_j^{(n)}, \quad i = 1, 2, 3. \end{aligned}$$

Again by Jensen's inequality, it can be shown that there is no loss of generality in assuming  $d_i(\omega) = d_i(\omega')$  in (22) if  $\omega, \omega' \in \Omega_m^{(n)}$  for some  $m$ . Therefore, one can readily see that  $\bar{\kappa}_n(\alpha, d_1, d_2, d_3) = \bar{\kappa}'_n(\alpha, d_1, d_2, d_3)$ . Note that

$$\begin{aligned} & \bar{\kappa}'_n(\alpha, d_1, d_2, d_3) \\ & \leq \inf \left\{ \frac{2\alpha-1}{4\pi} \int_{-\pi}^{\pi} \log \left( \frac{\bar{s}(\omega)}{d_1(\omega)} \right) d\omega \right. \\ & \quad \left. + \frac{1-\alpha}{4\pi} \int_{-\pi}^{\pi} \psi(\bar{s}(\omega), d_1(\omega), d_2(\omega), d_3(\omega)) d\omega \right\} \quad (23) \\ & \leq \tilde{\kappa} \left( \alpha, \frac{1}{1+\epsilon} \left( d_1 - \frac{1}{n} \sum_{j \in \mathcal{J}^{(n),c}} \lambda_j^{(n)} \right) \right), \end{aligned}$$

$$\begin{aligned} & \frac{1}{1+\epsilon} \left( d_2 - \frac{1}{n} \sum_{j \in \mathcal{J}^{(n),c}} \lambda_j^{(n)} \right), \\ & \frac{1}{1+\epsilon} \left( d_3 - \frac{1}{n} \sum_{j \in \mathcal{J}^{(n),c}} \lambda_j^{(n)} \right) \end{aligned} \quad (24)$$

where the infimum in (23) is over  $d_i(\omega), i = 1, 2, 3, \omega \in [-\pi, \pi]$ , subject to the constraints

$$\begin{aligned} & d_i(\omega) \in [0, \bar{s}(\omega)], \quad i = 1, 2, 3, \quad \omega \in [-\pi, \pi] \\ & \frac{1}{2\pi} \int_{-\pi}^{\pi} d_i(\omega) d\omega \leq d_i - \frac{1}{n} \sum_{j \in \mathcal{J}^{(n),c}} \lambda_j^{(n)}, \quad i = 1, 2, 3 \end{aligned}$$

and (24) follows from (16). Therefore, we have

$$\begin{aligned} & \kappa_n(\alpha, d_1, d_2, d_3) \\ & \leq \tilde{\kappa} \left( \alpha, \frac{1}{1+\epsilon} \left( d_1 - \frac{1}{n} \sum_{j \in \mathcal{J}^{(n),c}} \lambda_j^{(n)} \right) \right), \\ & \frac{1}{1+\epsilon} \left( d_2 - \frac{1}{n} \sum_{j \in \mathcal{J}^{(n),c}} \lambda_j^{(n)} \right), \\ & \frac{1}{1+\epsilon} \left( d_3 - \frac{1}{n} \sum_{j \in \mathcal{J}^{(n),c}} \lambda_j^{(n)} \right) \end{aligned} \quad (25)$$

Similarly, we have

$$\begin{aligned} & \kappa_n(\alpha, d_1, d_2, d_3) \\ & \geq \min \left\{ \frac{2\alpha-1}{2n} \sum_{j=1}^n \log \left( \frac{\lambda_j^{(n)}}{d_{1,j}} \right) \right. \\ & \quad \left. + \frac{1-\alpha}{2n} \sum_{j=1}^n \psi(\lambda_j^{(n)}, d_{1,j}, d_{2,j}, d_{3,j}) \right\} \quad (26) \\ & \geq \min \left\{ \frac{2\alpha-1}{2n} \sum_{m=1}^{M-1} \sum_{j \in \mathcal{J}_m^{(n)}} \log \left( \frac{\beta_m}{d_{1,j}} \right) \right. \\ & \quad \left. + \frac{1-\alpha}{2n} \sum_{m=1}^{M-1} \sum_{j \in \mathcal{J}_m^{(n)}} \psi(\beta_m, d_{1,j}, d_{2,j}, d_{3,j}) \right\} \\ & \triangleq \underline{\kappa}_n(\alpha, d_1, d_2, d_3) \end{aligned} \quad (27)$$

where the minimization in (26) is over  $d_{i,j} (i = 1, 2, 3; j = 1, \dots, n)$  subject to the constraints

$$\begin{aligned} & d_{i,j} \in [0, \lambda_j^{(n)}], \quad i = 1, 2, 3, \quad j = 1, \dots, n \\ & \frac{1}{n} \sum_{j=1}^n d_{i,j} \leq d_i, \quad i = 1, 2, 3 \end{aligned}$$

and the minimization in (27) is over  $d_{i,j} (i = 1, 2, 3; j \in \mathcal{J}^{(n)})$  subject to the constraints

$$\begin{aligned} & d_{i,j} \in [0, \lambda_j^{(n)}], \quad i = 1, 2, 3, \quad j \in \mathcal{J}^{(n)} \\ & \frac{1}{n} \sum_{j \in \mathcal{J}^{(n)}} d_{i,j} \leq d_i, \quad i = 1, 2, 3. \end{aligned}$$

It can be verified that

$$\begin{aligned} \underline{\kappa}_n(\alpha, d_1, d_2, d_3) &= \min \left\{ \frac{2\alpha - 1}{4\pi} \sum_{m=1}^{M-1} \int_{\Omega_m^{(n)}} \log \left( \frac{\beta_m}{d_1(\omega)} \right) d\omega \right. \\ &\quad \left. + \frac{1 - \alpha}{4\pi} \sum_{m=1}^{M-1} \int_{\Omega_m^{(n)}} \psi(\beta_m, d_1(\omega), d_2(\omega), d_3(\omega)) d\omega \right\} \end{aligned} \quad (28)$$

$$\begin{aligned} &\geq \inf \left\{ \frac{2\alpha - 1}{4\pi} \int_{-\pi}^{\pi} \log \left( \frac{\underline{s}(\omega)}{d_1(\omega)} \right) d\omega \right. \\ &\quad \left. + \frac{1 - \alpha}{4\pi} \int_{-\pi}^{\pi} \psi(\underline{s}(\omega), d_1(\omega), d_2(\omega), d_3(\omega)) d\omega \right\} \end{aligned} \quad (29)$$

$$\begin{aligned} &\geq \tilde{\kappa} \left( \alpha, (1 + \epsilon) \left( d_1 + \frac{1}{2\pi} \int_{\Omega^{(n),c}} s(\omega) d\omega \right), \right. \\ &\quad (1 + \epsilon) \left( d_2 + \frac{1}{2\pi} \int_{\Omega^{(n),c}} s(\omega) d\omega \right), \\ &\quad \left. (1 + \epsilon) \left( d_3 + \frac{1}{2\pi} \int_{\Omega^{(n),c}} s(\omega) d\omega \right) \right) \end{aligned} \quad (30)$$

where the minimization in (28) is over  $d_i(\omega)$ ,  $i = 1, 2, 3$ ,  $\omega \in \Omega^{(n)}$ , subject to the constraints

$$\begin{aligned} d_i(\omega) &\in [0, \underline{s}(\omega)], \quad i = 1, 2, 3, \quad \omega \in \Omega^{(n)} \\ \frac{1}{2\pi} \int_{\Omega^{(n)}} d_i(\omega) d\omega &\leq d_i, \quad i = 1, 2, 3; \end{aligned}$$

the infimum in (29) is over  $d_i(\omega)$ ,  $i = 1, 2, 3$ ,  $\omega \in [-\pi, \pi]$ , subject to the constraints

$$\begin{aligned} d_i(\omega) &\in [0, \underline{s}(\omega)], \quad i = 1, 2, 3, \quad \omega \in [-\pi, \pi] \\ \frac{1}{2\pi} \int_{-\pi}^{\pi} d_i(\omega) d\omega &\leq d_i + \frac{1}{2\pi} \int_{\Omega^{(n),c}} s(\omega) d\omega, \quad i = 1, 2, 3; \end{aligned}$$

and (30) follows from (16). Therefore

$$\begin{aligned} \kappa_n(\alpha, d_1, d_2, d_3) &\geq \tilde{\kappa} \left( \alpha, (1 + \epsilon) \left( d_1 + \frac{1}{2\pi} \int_{\Omega^{(n),c}} s(\omega) d\omega \right), \right. \\ &\quad (1 + \epsilon) \left( d_2 + \frac{1}{2\pi} \int_{\Omega^{(n),c}} s(\omega) d\omega \right), \\ &\quad \left. (1 + \epsilon) \left( d_3 + \frac{1}{2\pi} \int_{\Omega^{(n),c}} s(\omega) d\omega \right) \right). \end{aligned} \quad (31)$$

By the construction of  $\mathcal{J}_m^{(n)}$  and  $\Omega_m^{(n)}$ , it is clear that

$$\begin{aligned} \frac{1}{2\pi} \mu(\Omega_m^{(n)}) &= \frac{|\mathcal{J}_m^{(n)}|}{n} \\ &= \frac{|\mathcal{S}_m^{(n)}|}{n} \quad \text{if } \frac{|\mathcal{S}_m^{(n)}|}{n} \leq \frac{1}{2\pi} \mu(\Omega_m), \\ \frac{1}{2\pi} \mu(\Omega_m^{(n)}) &= \frac{|\mathcal{J}_m^{(n)}|}{n} \leq \frac{1}{2\pi} \mu(\Omega_m) \\ &\leq \frac{|\mathcal{J}_m^{(n)}| + 1}{n} \quad \text{if } \frac{|\mathcal{S}_m^{(n)}|}{n} > \frac{1}{2\pi} \mu(\Omega_m). \end{aligned}$$

In view of (17), one can readily show by invoking Lemma 6 that

$$\begin{aligned} \lim_{n \rightarrow \infty} \frac{1}{n} |\mathcal{S}_m^{(n)}| &= \lim_{n \rightarrow \infty} \frac{1}{n} |\mathcal{J}_m^{(n)}| = \lim_{n \rightarrow \infty} \frac{1}{2\pi} \mu(\Omega_m^{(n)}) \\ &= \frac{1}{2\pi} \mu(\Omega_m), \quad m = 1, \dots, M-1 \end{aligned}$$

which implies

$$\begin{aligned} \lim_{n \rightarrow \infty} \frac{1}{n} |\mathcal{S}_m^{(n)} \setminus \mathcal{J}_m^{(n)}| &= \lim_{n \rightarrow \infty} \frac{1}{n} (|\mathcal{S}_m^{(n)}| - |\mathcal{J}_m^{(n)}|) = 0, \quad m = 1, \dots, M-1 \\ \lim_{n \rightarrow \infty} \frac{1}{2\pi} \mu(\Omega_m \setminus \Omega_m^{(n)}) &= \lim_{n \rightarrow \infty} \frac{1}{2\pi} (\mu(\Omega_m) - \mu(\Omega_m^{(n)})) = 0, \quad m = 1, \dots, M-1. \end{aligned}$$

Since  $\lambda_j^{(n)} \in (\beta_1, \beta_M]$  ( $j \in \mathcal{S}_m^{(n)} \setminus \mathcal{J}_m^{(n)}$ ) and  $s(\omega) \in (\beta_1, \beta_M]$  ( $\omega \in \Omega_m \setminus \Omega_m^{(n)}$ ) for  $m = 1, \dots, M-1$ , it follows that

$$\begin{aligned} \lim_{n \rightarrow \infty} \frac{1}{n} \sum_{m=1}^{M-1} \sum_{j \in \mathcal{S}_m^{(n)} \setminus \mathcal{J}_m^{(n)}} \lambda_j^{(n)} &= 0 \\ \lim_{n \rightarrow \infty} \frac{1}{2\pi} \sum_{m=1}^{M-1} \int_{\Omega_m \setminus \Omega_m^{(n)}} s(\omega) d\omega &= 0. \end{aligned}$$

Furthermore, by Lemma 6,

$$\begin{aligned} \lim_{n \rightarrow \infty} \frac{1}{n} \sum_{j=1}^n \lambda_j^{(n)} \left( \mathbb{1}(\lambda_j^{(n)} \leq \beta_1) + \mathbb{1}(\lambda_j^{(n)} > \beta_M) \right) \\ = \frac{1}{2\pi} \int_{s(\omega) \leq \beta_1} s(\omega) d\omega + \frac{1}{2\pi} \int_{s(\omega) > \beta_M} s(\omega) d\omega. \end{aligned}$$

Therefore, we have

$$\begin{aligned} \lim_{n \rightarrow \infty} \frac{1}{n} \sum_{j \in \mathcal{J}^{(n),c}} \lambda_j^{(n)} &= \lim_{n \rightarrow \infty} \frac{1}{n} \sum_{j=1}^n \lambda_j^{(n)} \left( \mathbb{1}(\lambda_j^{(n)} \leq \beta_1) + \mathbb{1}(\lambda_j^{(n)} > \beta_M) \right) \\ &\quad + \frac{1}{n} \sum_{m=1}^{M-1} \sum_{j \in \mathcal{S}_m^{(n)} \setminus \mathcal{J}_m^{(n)}} \lambda_j^{(n)} \\ &= \frac{1}{2\pi} \int_{s(\omega) \leq \beta_1} s(\omega) d\omega + \frac{1}{2\pi} \int_{s(\omega) > \beta_M} s(\omega) d\omega \\ &\leq 2\epsilon \end{aligned} \quad (32)$$

and

$$\begin{aligned} \lim_{n \rightarrow \infty} \frac{1}{2\pi} \int_{\Omega^{(n),c}} s(\omega) d\omega &= \lim_{n \rightarrow \infty} \frac{1}{2\pi} \int_{s(\omega) \leq \beta_1} s(\omega) d\omega + \frac{1}{2\pi} \int_{s(\omega) > \beta_M} s(\omega) d\omega \\ &\quad + \frac{1}{2\pi} \sum_{m=1}^{M-1} \int_{\Omega_m \setminus \Omega_m^{(n)}} s(\omega) d\omega \\ &= \frac{1}{2\pi} \int_{s(\omega) \leq \beta_1} s(\omega) d\omega + \frac{1}{2\pi} \int_{s(\omega) > \beta_M} s(\omega) d\omega \\ &\leq 2\epsilon \end{aligned} \quad (33)$$

where (32) (as well as (33)) follows from (18) and (19). In view of (25), (31), and the fact that  $\tilde{\kappa}(\alpha, d_1, d_2, d_3)$  is a continuous function of  $(d_1, d_2, d_3)$  (cf. Lemma 3), the proof is complete.  $\square$

The method used to establish  $\bar{\kappa}_n(\alpha, d_1, d_2, d_3) = \bar{\kappa}'_n(\alpha, d_1, d_2, d_3)$  in the Proof of Theorem 4 can be leveraged to show the following fact: if  $s(\omega)$  is a piecewise constant function, then  $\kappa(\alpha, d_1, d_2, d_3)$  can be computed by solving a convex optimization problem similar to the one associated with  $\kappa_n(\alpha, d_1, d_2, d_3)$ . In general, we can approximate  $s(\omega)$  from above and below with arbitrary accuracy by piecewise constant spectral density functions. Furthermore, it is easy to see that for any spectral density functions  $s_1(\omega)$  and  $s_2(\omega)$ , with  $s_1(\omega) \geq s(\omega) \geq s_2(\omega)$ ,  $\omega \in [-\pi, \pi)$ , we have  $\kappa(\alpha, d_1, d_2, d_3)|_{s_1(\omega)} \geq \kappa(\alpha, d_1, d_2, d_3)|_{s(\omega)} \geq \kappa(\alpha, d_1, d_2, d_3)|_{s_2(\omega)}$ . Therefore, the spectral domain characterization effectively provides a way to compute  $\kappa(\alpha, d_1, d_2, d_3)$ .

VI. CONCLUSION

The 2-description rate region for stationary Gaussian sources under the squared error distortion measure is characterized. In view of the extremal properties of the Gaussian processes and the standard high resolution analysis [10], the results in the present work have clear implications on multiple description coding for general stationary sources with finite differential entropy rate under the squared error distortion measure.

APPENDIX

In this appendix, we provide an outline on how to construct fixed-rate codes without common random dithers from the randomized dithered quantization scheme using variable-rate codes. By Carathéodory's theorem, there exist dither pairs  $(z_{1,k}^n, z_{2,k}^n)$ ,  $k = 1, \dots, 6$ , and  $\xi_k \in [0, 1]$ ,  $k = 1, \dots, 6$ , with  $\sum_{k=1}^6 \xi_k = 1$  such that

$$\begin{aligned} & \frac{1}{n} \sum_{k=1}^6 \xi_k H \left( Q_n \left( A_3^{-1} \tilde{X}^n + Z_1^n \right) \middle| Z_1^n = z_{1,k}^n \right) = r_1^{(n)} \\ & \frac{1}{n} \sum_{k=1}^6 \xi_k H \left( Q_n \left( A_4^{-1} \left( A_1 \tilde{X}^n + A_2 W_1^n \right) + Z_2^n \right) \middle| Z_1^n = z_{1,k}^n, Z_2^n = z_{2,k}^n \right) = r_2^{(n)} \\ & \frac{1}{n} \sum_{k=1}^6 \xi_k \mathbb{E} \left[ \left\| X^n - \hat{X}_i^n \right\|^2 \middle| Z_1^n = z_{1,k}^n, Z_2^n = z_{2,k}^n \right] \\ & = \frac{1}{n} \mathbb{E} \left[ \left\| X^n - \hat{X}_i^n \right\|^2 \right] \leq d_i, \quad i = 1, 2, 3. \end{aligned}$$

Therefore, for any  $\epsilon > 0$ , one can construct encoding functions  $f_1^{(m)}(\cdot)$  and  $f_2^{(m)}(\cdot)$  for some  $m$  by suitably concatenating quantizers and dither sequences such that

$$\frac{1}{m} H \left( f_i^{(m)}(X^m) \right) \leq r_i^{(n)} + \epsilon, \quad i = 1, 2$$

$$\begin{aligned} & \frac{1}{m} \mathbb{E} \left[ \left\| X^m - \mathbb{E} \left[ X^m \middle| f_i^{(m)}(X^m) \right] \right\|^2 \right] \\ & \leq d_i + \epsilon, \quad i = 1, 2, \\ & \frac{1}{m} \mathbb{E} \left[ \left\| X^m - \mathbb{E} \left[ X^m \middle| f_1^{(m)}(X^m), f_2^{(m)}(X^m) \right] \right\|^2 \right] \\ & \leq d_3 + \epsilon. \end{aligned}$$

Now construct functions  $f_1^{(\ell m)}(\cdot)$  and  $f_2^{(\ell m)}(\cdot)$  by repeating  $f_1^{(m)}(\cdot)$  and  $f_2^{(m)}(\cdot)$  over  $\ell$  blocks. Let

$$\begin{aligned} \mathcal{A}_{\ell m} = & \left\{ x^{\ell m} : -\frac{1}{\ell m} \log \left( \Pr \left\{ f_1^{(\ell m)}(X^{\ell m}) = f_1^{(\ell m)}(x^{\ell m}) \right\} \right) \right. \\ & \geq \frac{1}{m} H \left( f_1^{(m)}(X^m) \right) + \epsilon \\ & \text{or } -\frac{1}{\ell m} \log \left( \Pr \left\{ f_2^{(\ell m)}(X^{\ell m}) = f_2^{(\ell m)}(x^{\ell m}) \right\} \right) \\ & \left. \geq \frac{1}{m} H \left( f_2^{(m)}(X^m) \right) + \epsilon \right\}. \end{aligned}$$

Define a pair of encoding functions  $\tilde{f}_1^{(\ell m)}(\cdot)$  and  $\tilde{f}_2^{(\ell m)}(\cdot)$  such that

$$\tilde{f}_i^{(\ell m)}(x^{\ell m}) = \begin{cases} \text{a special symbol,} & x^{\ell m} \in \mathcal{A}_{\ell m} \\ f_i^{(\ell m)}(x^{\ell m}), & \text{otherwise} \end{cases} \quad i = 1, 2.$$

Let  $\tilde{g}_i^{(\ell m)} \left( \tilde{f}_i^{(\ell m)}(x^{\ell m}) \right)$  be defined as shown at the bottom of the page. It is clear that

$$\frac{1}{\ell m} \log \left| \tilde{f}_i^{(\ell m)} \right| \leq \frac{1}{m} H \left( f_i^{(m)}(X^m) \right) + 2\epsilon \leq r_i^{(n)} + 3\epsilon, \quad i = 1, 2$$

when  $\ell$  is sufficiently large. Moreover, we have

$$\begin{aligned} & \frac{1}{\ell m} \mathbb{E} \left[ \left\| X^{\ell m} - \mathbb{E} \left[ X^{\ell m} \middle| \tilde{f}_i^{(\ell m)}(X^{\ell m}) \right] \right\|^2 \right] \\ & \leq \frac{1}{\ell m} \mathbb{E} \left[ \left\| X^{\ell m} - \tilde{g}_i^{(\ell m)} \left( \tilde{f}_i^{(\ell m)}(X^{\ell m}) \right) \right\|^2 \right] \\ & = \frac{1}{\ell m} \mathbb{E} \left[ \mathbb{1}(X^{\ell m} \in \mathcal{A}_{\ell m}) \left\| X^{\ell m} - \tilde{g}_i^{(\ell m)} \left( \tilde{f}_i^{(\ell m)}(X^{\ell m}) \right) \right\|^2 \right] \\ & \quad + \frac{1}{\ell m} \mathbb{E} \left[ \mathbb{1}(X^{\ell m} \notin \mathcal{A}_{\ell m}) \left\| X^{\ell m} - \tilde{g}_i^{(\ell m)} \left( \tilde{f}_i^{(\ell m)}(X^{\ell m}) \right) \right\|^2 \right] \\ & = \frac{1}{\ell m} \mathbb{E} \left[ \mathbb{1}(X^{\ell m} \in \mathcal{A}_{\ell m}) \left\| X^{\ell m} \right\|^2 \right] \\ & \quad + \frac{1}{\ell m} \mathbb{E} \left[ \mathbb{1}(X^{\ell m} \notin \mathcal{A}_{\ell m}) \left\| X^{\ell m} - \mathbb{E} \left[ X^{\ell m} \middle| f_i^{(\ell m)}(X^{\ell m}) \right] \right\|^2 \right] \\ & \leq \frac{1}{\ell m} \mathbb{E} \left[ \mathbb{1}(X^{\ell m} \in \mathcal{A}_{\ell m}) \left\| X^{\ell m} \right\|^2 \right] \end{aligned}$$

---

$$\tilde{g}_i^{(\ell m)} \left( \tilde{f}_i^{(\ell m)}(x^{\ell m}) \right) = \begin{cases} 0^{\ell m}, & \tilde{f}_i^{(\ell m)}(x^{\ell m}) = \text{special symbol} \\ \mathbb{E} \left[ X^{\ell m} \middle| f_i^{(\ell m)}(X^{\ell m}) = f_i^{(\ell m)}(x^{\ell m}) \right], & \text{otherwise} \end{cases} \quad i = 1, 2.$$

$$\begin{aligned}
& + \frac{1}{\ell m} \mathbb{E} \left[ \left\| X^{\ell m} - \mathbb{E} \left[ X^{\ell m} \mid f_i^{(\ell m)}(X^{\ell m}) \right] \right\|^2 \right] \\
& \leq \frac{1}{\ell m} \mathbb{E} \left[ \mathbb{I}(X^{\ell m} \in \mathcal{A}_{\ell m}) \|X^{\ell m}\|^2 \right] + d_i + \epsilon, \quad i = 1, 2
\end{aligned}$$

where  $\mathbb{I}(\cdot)$  is the indicator function. Note that for any  $\rho \geq 0$

$$\begin{aligned}
& \frac{1}{\ell m} \mathbb{E} \left[ \mathbb{I}(X^{\ell m} \in \mathcal{A}_{\ell m}) \|X^{\ell m}\|^2 \right] \\
& = \frac{1}{\ell m} \mathbb{E} \left[ \mathbb{I}(X^{\ell m} \in \mathcal{A}_{\ell m}) \right. \\
& \quad \left. \sum_{j=1}^{\ell m} \|X(j)\|^2 \mathbb{I}(\|X(j)\|^2 \geq \rho) \right] \\
& + \frac{1}{\ell m} \mathbb{E} \left[ \mathbb{I}(X^{\ell m} \in \mathcal{A}_{\ell m}) \right. \\
& \quad \left. \sum_{j=1}^{\ell m} \|X(j)\|^2 \mathbb{I}(\|X(j)\|^2 < \rho) \right] \\
& \leq \frac{1}{\ell m} \mathbb{E} \left[ \sum_{j=1}^{\ell m} \|X(j)\|^2 \mathbb{I}(\|X(j)\|^2 \geq \rho) \right] \\
& + \rho \Pr\{X^{\ell m} \in \mathcal{A}_{\ell m}\} \\
& = \mathbb{E}[\|X(1)\|^2 \mathbb{I}(\|X(1)\|^2 \geq \rho)] + \rho \Pr\{X^{\ell m} \in \mathcal{A}_{\ell m}\}.
\end{aligned} \tag{34}$$

By the monotone convergence theorem

$$\lim_{\rho \rightarrow \infty} \mathbb{E}[\|X(1)\|^2 \mathbb{I}(\|X(1)\|^2 \geq \rho)] = 0.$$

Thus, by choosing a sufficiently large  $\rho$ , we can make the first term in (34) less than  $\frac{\epsilon}{2}$ . Furthermore, since  $\{(X(km+1), \dots, X(km+m))^T\}_{k=0}^{\infty}$  is an ergodic vector process,<sup>3</sup> it follows from the Shannon–McMillan–Breiman theorem that  $\Pr\{X^{\ell m} \in \mathcal{A}_{\ell m}\} \rightarrow 0$  as  $\ell \rightarrow \infty$ . Hence, for any fixed  $\rho$ , the second term in (34) can also be bounded from above by  $\frac{\epsilon}{2}$  when  $\ell$  is large enough. Therefore, we have

$$\begin{aligned}
\frac{1}{\ell m} \mathbb{E} \left[ \left\| X^{\ell m} - \mathbb{E} \left[ X^{\ell m} \mid \tilde{f}_i^{(\ell m)}(X^{\ell m}) \right] \right\|^2 \right] & \leq d_i + 2\epsilon, \\
& i = 1, 2
\end{aligned}$$

for all sufficiently large  $\ell$ . Similarly, it can be shown that

$$\begin{aligned}
\frac{1}{\ell m} \mathbb{E} \left[ \left\| X^{\ell m} - \mathbb{E} \left[ X^{\ell m} \mid \tilde{f}_1^{(\ell m)}(X^{\ell m}), \tilde{f}_2^{(\ell m)}(X^{\ell m}) \right] \right\|^2 \right] \\
\leq d_3 + 2\epsilon
\end{aligned}$$

when  $\ell$  is sufficiently large. Since  $\lim_{n \rightarrow \infty} \alpha r_1^{(n)} + (1 - \alpha)r_2^{(n)} = \lim_{n \rightarrow \infty} \kappa_n(\alpha, d_1, d_2, d_3)$  and  $\epsilon > 0$  is arbitrary, one can readily complete the proof by invoking the fact that  $\kappa(\alpha, d_1, d_2, d_3)$  is a continuous function of  $(d_1, d_2, d_3)$ .

<sup>3</sup>This follows from the fact that the vector process obtained by arranging a weakly mixing process into blocks of length  $m$  is also weakly mixing [15].

## ACKNOWLEDGMENT

The authors wish to thank the anonymous reviewers and the associate editor, Dr. E. Ordentlich, for their constructive comments that helped to improve the presentation of the paper.

## REFERENCES

- [1] A. A. El Gamal and T. M. Cover, "Achievable rates for multiple descriptions," *IEEE Trans. Inf. Theory*, vol. IT-28, no. 6, pp. 851–857, Nov. 1982.
- [2] R. Ahlswede, "The rate-distortion region for multiple descriptions without excess rate," *IEEE Trans. Inf. Theory*, vol. IT-31, no. 6, pp. 721–726, Nov. 1985.
- [3] Z. Zhang and T. Berger, "New results in binary multiple descriptions," *IEEE Trans. Inf. Theory*, vol. IT-33, no. 4, pp. 502–521, July 1987.
- [4] L. Ozarow, "On a source coding problem with two channels and three receivers," *Bell Syst. Tech. J.*, vol. 59, no. 10, pp. 1909–1921, Dec. 1980.
- [5] R. Venkataramani, G. Kramer, and V. K. Goyal, "Multiple description coding with many channels," *IEEE Trans. Inf. Theory*, vol. 49, no. 9, pp. 2106–2114, Sep. 2003.
- [6] S. S. Pradhan, R. Puri, and K. Ramchandran, " $n$ -channel symmetric multiple descriptions—Part I:  $(n, k)$  source-channel erasure codes," *IEEE Trans. Inf. Theory*, vol. 50, no. 1, pp. 47–61, Jan. 2004.
- [7] R. Puri, S. S. Pradhan, and K. Ramchandran, " $n$ -channel symmetric multiple descriptions—Part II: An achievable rate-distortion region," *IEEE Trans. Inf. Theory*, vol. 51, no. 4, pp. 1377–1392, Apr. 2005.
- [8] H. Wang and P. Viswanath, "Vector gaussian multiple description with individual and central receivers," *IEEE Trans. Inf. Theory*, vol. 53, no. 6, pp. 2133–2153, Jun. 2007.
- [9] X. Yang and K. Ramchandran, "Optimal subband filter banks for multiple description coding," *IEEE Trans. Inf. Theory*, vol. 46, no. 7, pp. 2477–2490, Nov. 2000.
- [10] R. Zamir, "Shannon-type bounds for multiple descriptions of a stationary source," *J. Comb., Inf. Syst. Sci.*, pp. 1–15, Dec. 2000.
- [11] P. L. Dragotti, S. D. Servetto, and M. Vetterli, "Optimal filter banks for multiple description coding: Analysis and synthesis," *IEEE Trans. Inf. Theory*, vol. 48, no. 7, pp. 2036–2052, Jul. 2002.
- [12] M. Fleming and M. Effros, "The rate distortion region for the multiple description problem," in *Proc. IEEE Int. Symp. Information Theory*, Sorrento, Italy, Jun. 2000, p. 208.
- [13] J. C. Taylor, *An Introduction to Measure and Probability*. New York: Springer, 1997.
- [14] G. Maruyama, "The harmonic analysis of stationary stochastic processes," *Memoirs of the Faculty of Science, Series A, Mathematics*, vol. 4, no. 1, pp. 45–106, 1949.
- [15] V. Sethuraman and B. Hajek, "Capacity per unit energy of fading channels with a peak constraint," *IEEE Trans. Inf. Theory*, vol. 51, no. 9, pp. 3102–3120, Sep. 2005.
- [16] K. Hoffman, *Banach Spaces of Analytic Functions*. New York: Prentice-Hall, 1962.
- [17] S. N. Diggavi and T. M. Cover, "The worst additive noise under a covariance constraint," *IEEE Trans. Inf. Theory*, vol. 47, no. 7, pp. 3072–3081, Nov. 2001.
- [18] J. Chen, C. Tian, T. Berger, and S. S. Hemami, "Multiple description quantization via Gram–Schmidt orthogonalization," *IEEE Trans. Inf. Theory*, vol. 52, no. 12, pp. 5197–5217, Dec. 2006.
- [19] Y. Frank-Dayana and R. Zamir, "Dithered lattice-based quantizers for multiple descriptions," *IEEE Trans. Inf. Theory*, vol. 48, no. 1, pp. 192–204, Jan. 2002.
- [20] U. Grenander and G. Szegő, *Toeplitz Forms and Their Applications*. Providence, RI: AMS Chelsea, 1958.
- [21] R. M. Gray, "Toeplitz and circulant matrices: A review," *Foundations and Trends in Communications and Information Theory*, vol. 2, pp. 155–239, 2006.

**Jun Chen** (S'03–M'06) received the B.E. degree with honors in communication engineering from Shanghai Jiao Tong University, Shanghai, China, in 2001 and the M.S. and Ph.D. degrees in electrical and computer engineering from Cornell University, Ithaca, NY, in 2003 and 2006, respectively.

He was a Postdoctoral Research Associate in the Coordinated Science Laboratory at the University of Illinois at Urbana-Champaign, Urbana, IL, from 2005 to 2006, and a Josef Raviv Memorial Postdoctoral Fellow at the IBM Thomas J. Watson Research Center, Yorktown Heights, NY, from 2006 to 2007. He is currently an Assistant Professor of Electrical and Computer Engineering at McMaster University, Hamilton, ON, Canada. He holds the Barber-Gennum Chair

in Information Technology. His research interests include information theory, wireless communications, and signal processing.

**Chao Tian** (S'00–M'05) received the B.S. degree in electronic engineering from Tsinghua University, Beijing, China, in 2000 and the M.S. and Ph.D. degrees in electrical and computer engineering from Cornell University, Ithaca, NY, in 2003 and 2005, respectively.

He was a Postdoctoral Researcher at Ecole Polytechnique Fédérale de Lausanne (EPFL), Lausanne, Switzerland, from 2005 to 2007. He joined AT&T Labs–Research, Florham Park, NJ, in 2007, where he is now a Senior Member of Technical Staff. His research interests include multiuser information theory, joint source–channel coding, quantization design and analysis, as well as image/video coding and processing.

**Suhas N. Diggavi** (S'93–M'99) received the B.Tech. degree in electrical engineering from the Indian Institute of Technology, Delhi, India and the Ph.D. degree in electrical engineering from Stanford University, Stanford, CA, in 1998.

After completing his Ph.D. study, he was a Principal Member of Technical Staff in the Information Sciences Center, AT&T Shannon Laboratories, Florham Park, NJ. He is currently with the faculty of the School of Computer and Communication Sciences, EPFL, Lausanne, Switzerland, where he heads the Laboratory for Information and Communication Systems (LICOS). His research interests include wireless communications, information theory, source coding, and signal processing.

Dr. Diggavi is a recipient of the 2006 IEEE Donald Fink award, the 2005 IEEE Vehicular Technology Conference best paper award, and the Okawa foundation research award.